

THIS DRAWING IS UNPUBLISHED. RELEASED FOR PUBLICATION
 © COPYRIGHT BY TYCO ELECTRONICS CORPORATION. ALL RIGHTS RESERVED.

LOC	DIST	REVISIONS			
P	LTR	DESCRIPTION	DATE	DWN	APVD
GP	00				
	H	REVISED PER ECO-06-028338	11/DEC/06	ZMR	EDB

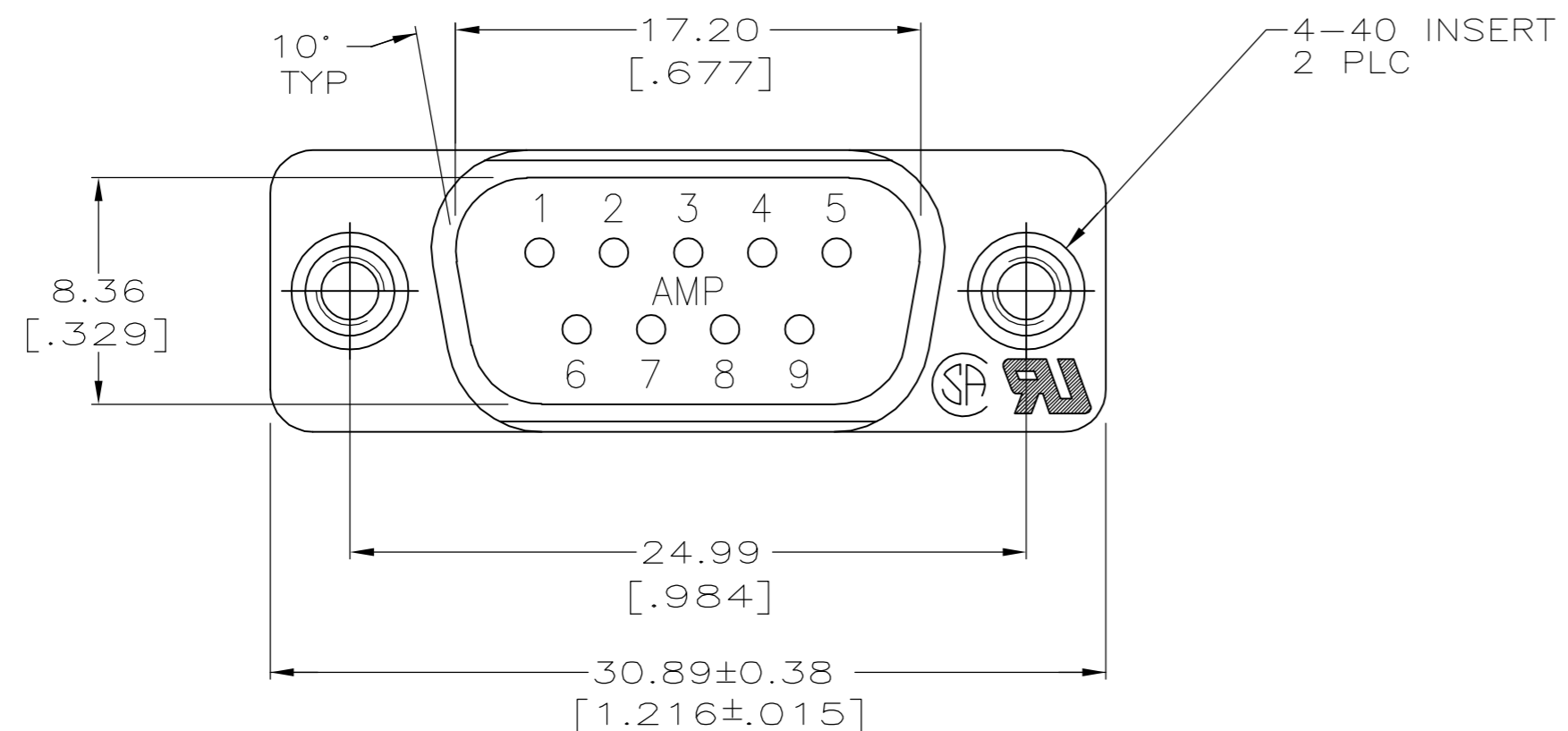

- ① HOUSING: BLACK POLYESTER, UL 94V-0 RATED;
CONTACTS: BRASS
INSERTS: BRASS
- ② GOLD PLATED FOR LENGTH OF 3.81 [.150] MIN FROM MATING END, GOLD FLASH IN MATED AREA, 2.54µm [.000100] MIN TIN OR TIN-LEAD FOR A LENGTH OF DIMENSION A FROM OPPOSITE END, BOTH OVER 1.27µm [.000050] MIN NICKEL.
- ③ GOLD PLATED FOR LENGTH OF 3.81 [.150] MIN FROM MATING END, 0.76µm [.000030] MIN GOLD IN MATED AREA, 2.54µm [.000100] MIN TIN OR TIN-LEAD FOR A LENGTH OF DIMENSION A FROM OPPOSITE END, BOTH OVER 1.27µm [.000050] MIN NICKEL.
-OR-
GOLD FLASH OVER PALLADIUM NICKEL FOR A LENGTH OF 3.81 [.150] MIN FROM MATING END, 0.76µm [.000030] MIN PALLADIUM NICKEL IN MATED AREA, 2.54µm [.000100] MIN TIN OR TIN-LEAD FOR A LENGTH OF DIMENSION A FROM OPPOSITE END, BOTH OVER 1.27µm [.000050] MIN NICKEL.

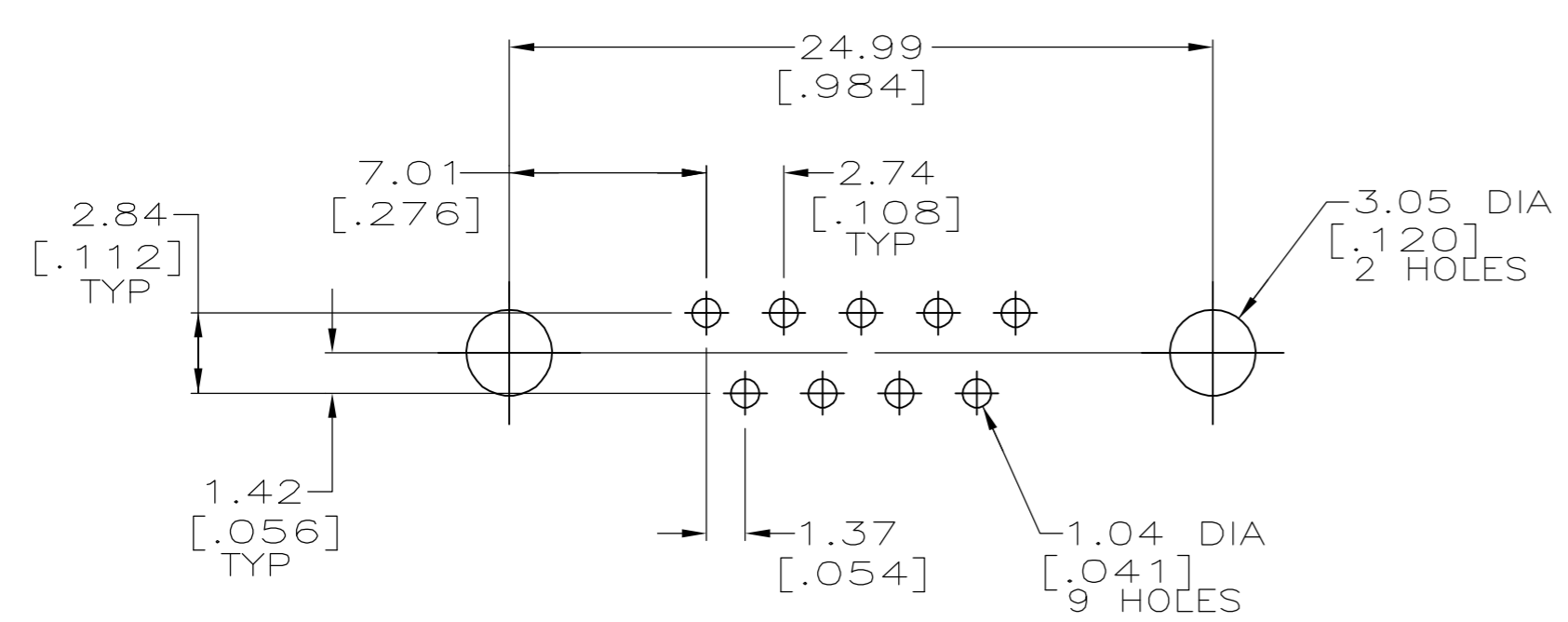
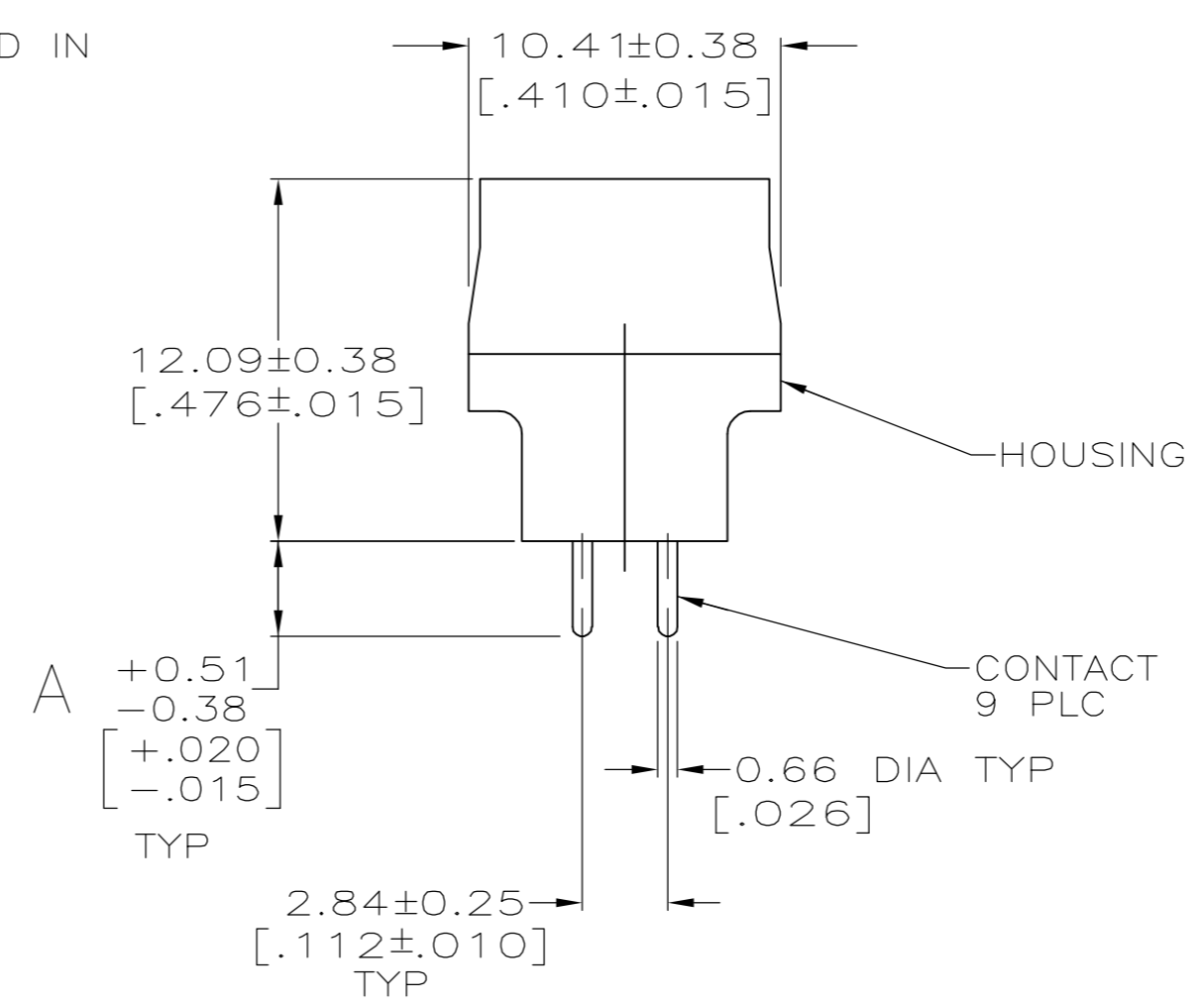
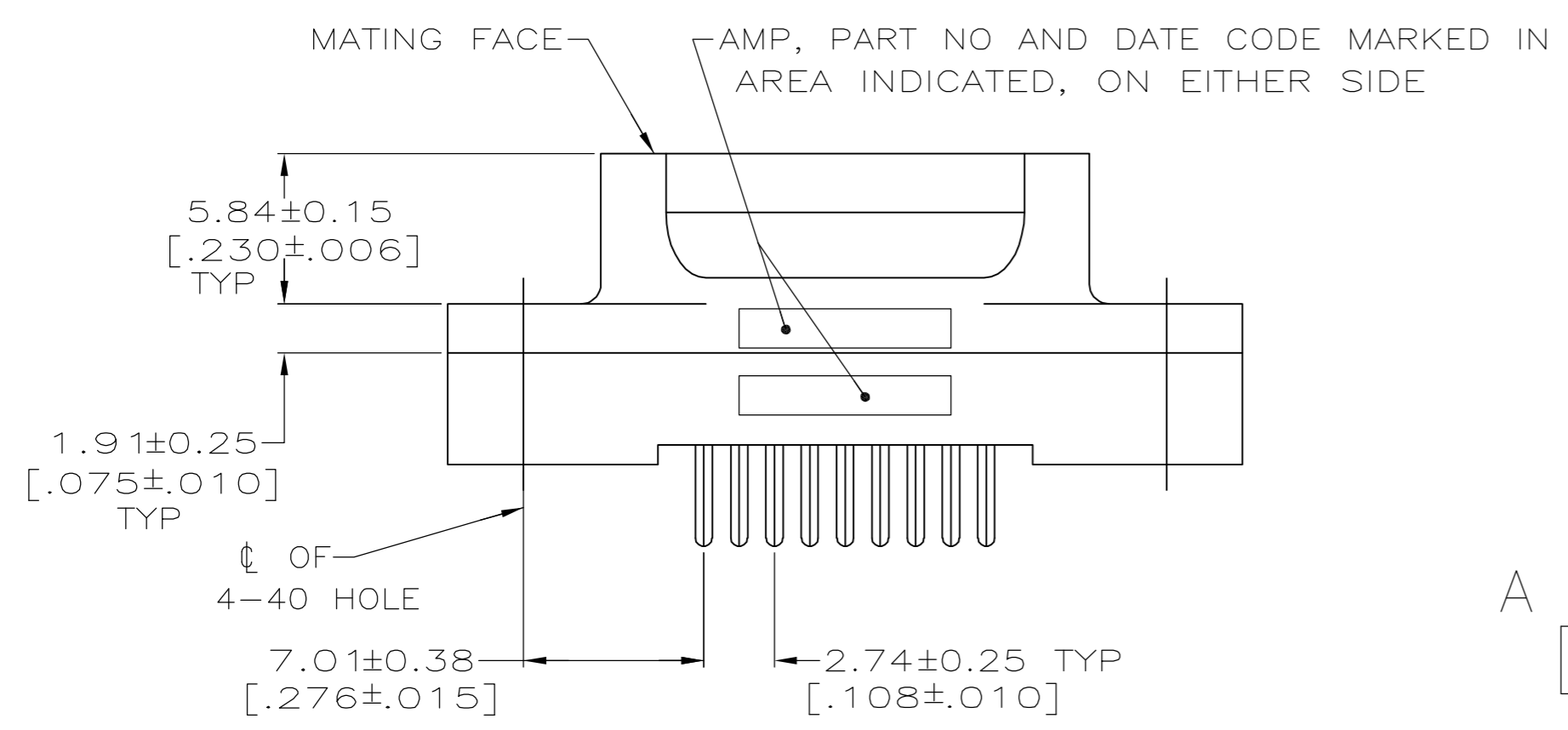

RECOMMENDED PC BOARD MOUNTING DIMENSIONS

	DIMENSION A	CONTACT FINISH	PART NUMBER
OBSOLETE	6.35 [.250]	③	745051-6
OBSOLETE	6.35 [.250]	②	745051-5
OBSOLETE	4.32 [.170]	③	745051-4
OBSOLETE	4.32 [.170]	②	745051-3
	3.18 [.125]	③	745051-2
	3.18 [.125]	②	745051-1

THIS DRAWING IS A CONTROLLED DOCUMENT.		DWN J McCLINTON 11-14-89	tyco Electronics Corporation Harrisburg, PA 17105-3608	
DIMENSIONS: mm [INCHES]		CHK R.STONE 2-1-90	NAME PLUG ASSEMBLY, SIZE 1, 9 POSN, VERTICAL, AMPLIMITE® HD-20	
TOLERANCES UNLESS OTHERWISE SPECIFIED:		APVD C. ROHDE 2-5-90	SIZE A2 CAGE CODE 00779 C=745051	
0 PLC ± -		PRODUCT SPEC 108-40025	DRAWING NO	
1 PLC ± -		APPLICATION SPEC	RESTRICTED TO	
2 PLC ± 0.13 [.005]			SCALE 4:1 SHEET 1 OF 1 REV H	
3 PLC ± -				
4 PLC ± -				
ANGLES ± 2°				
FINISH		WEIGHT -		
CONTACTS: SEE TABLE		CUSTOMER DRAWING		