

National Semiconductor is now part of
Texas Instruments.

Search <http://www.ti.com/> for the latest technical
information and details on our current products and services.

5.0V Reference Diode

General Description

The LM136A-5.0QML/LM136-5.0QML integrated circuits are precision 5.0V shunt regulator diodes. These monolithic IC voltage references operate as a low temperature coefficient 5.0V zener with 0.6Ω dynamic impedance. A third terminal on the LM136-5.0 allows the reference voltage and temperature coefficient to be trimmed easily.

The LM136-5.0 series is useful as a precision 5.0V low voltage reference for digital voltmeters, power supplies or op amp circuitry. The 5.0V makes it convenient to obtain a stable reference from low voltage supplies. Further, since the LM136-5.0 operates as a shunt regulator, it can be used as either a positive or negative voltage reference.

Features

- Adjustable 4V to 6V
- Low temperature coefficient
- Wide operating current of 600 μA to 10 mA
- 0.6Ω dynamic impedance
- Guaranteed temperature stability
- Easily trimmed for minimum temperature drift
- Fast turn-on
- Three lead transistor package

Ordering Information

NS Part Number	SMD Part Number	NS Package Number	Package Description
LM136H-5.0/883		H03H	T0-46, 3LD Metal Can
LM136AH-5.0/883		H03H	T0-46, 3LD Metal Can
LM136AH-5.0-SMD	8418002XA	H03H	T0-46, 3LD Metal Can

Connection Diagram

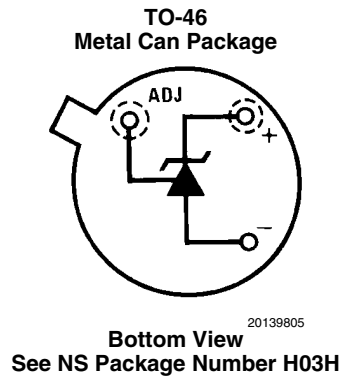

Schematic Diagram

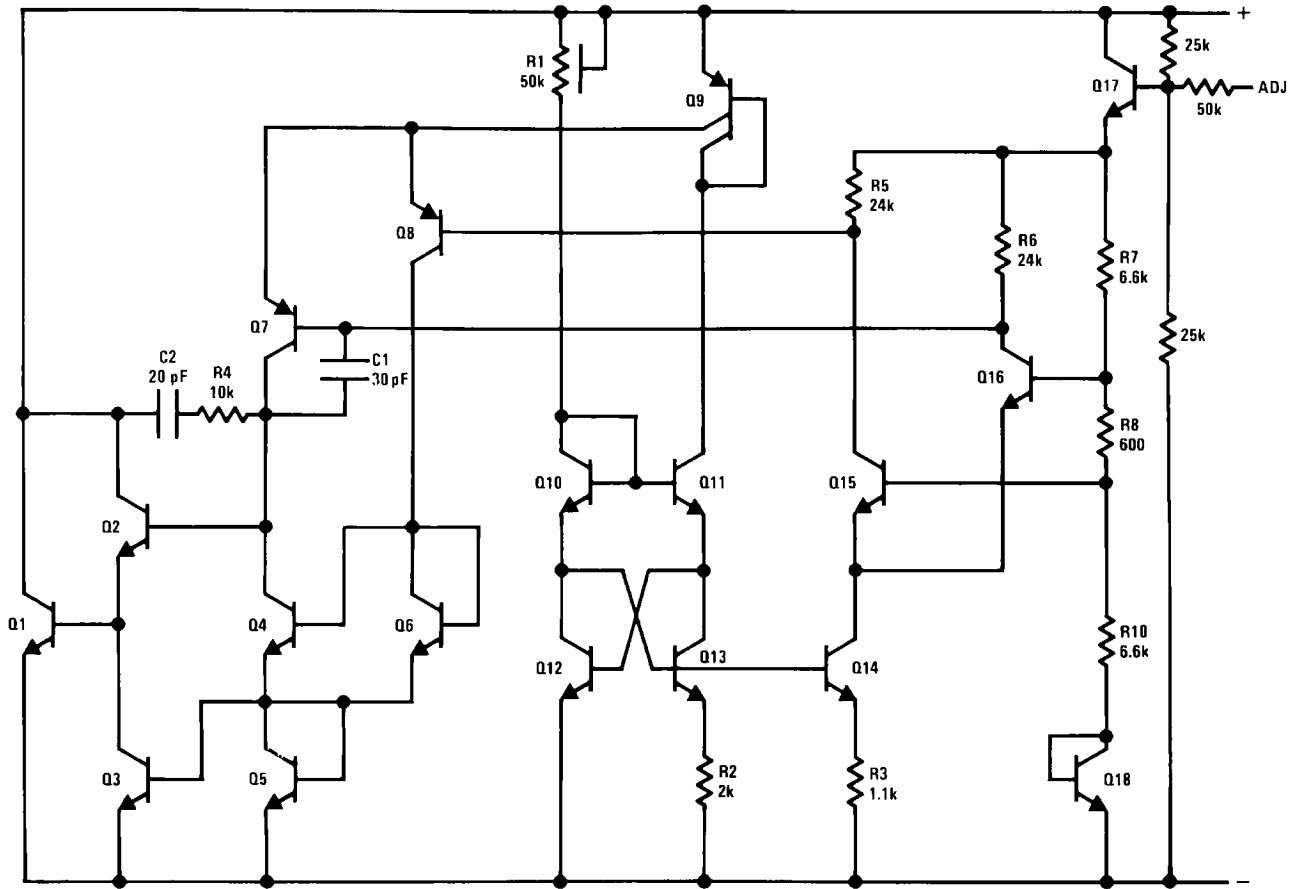

20139816

Typical Applications

5.0V Reference

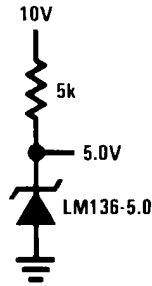

20139801

5.0V Reference with Minimum Temperature Coefficient

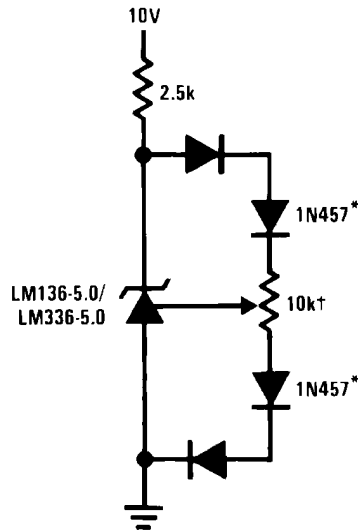

20139815

† Adjust to 5.00V

* Any silicon signal diode

Trimmed 4V to 6V Reference with Temperature Coefficient Independent of Breakdown Voltage

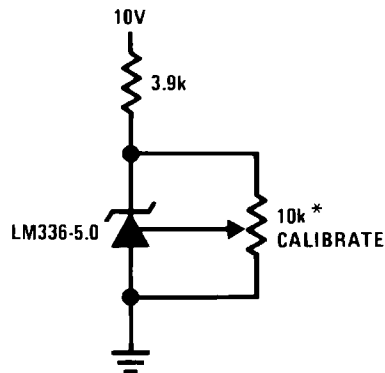

20139803

* Does not affect temperature coefficient

Absolute Maximum Ratings *(Note 1)*

Reverse Current	15mA
Forward Current	15mA
Storage Temperature	$-60^{\circ}\text{C} \leq T_A \leq +150^{\circ}\text{C}$
Operating Temperature Range <i>(Note 2)</i>	$-55^{\circ}\text{C} \leq T_A \leq +125^{\circ}\text{C}$
Soldering Information (10 Seconds)	300°C
Maximum Junction Temperature (T_{Jmax})	150°C
Thermal Resistance	
θ_{JA}	
Still Air Flow	354°C/W
500LF/Min Air Flow	77°C/W
θ_{JC}	46°C/W
ESD Rating <i>(Note 3)</i>	1,000 V

Quality Conformance Inspection

Mil-Std-883, Method 5005 - Group A

Subgroup	Description	Temp°C
1	Static tests at	+25
2	Static tests at	+125
3	Static tests at	-55
4	Dynamic tests at	+25
5	Dynamic tests at	+125
6	Dynamic tests at	-55
7	Functional tests at	+25
8A	Functional tests at	+125
8B	Functional tests at	-55
9	Switching tests at	+25
10	Switching tests at	+125
11	Switching tests at	-55
12	Settling time at	+25
13	Settling time at	+125
14	Settling time at	-55

LM136-5.0 Electrical Characteristics

DC Parameters

The following conditions apply, unless otherwise specified. $I_R = 1 \text{ mA}$

Symbol	Parameter	Conditions	Notes	Min	Max	Unit	Sub-groups
V_R	Reverse Breakdown Voltage	$V_{Adj} = 2.5V$		4.6	5.4	V	1
				4.8	5.6	V	2, 3
		$V_{Adj} = 1.5V$		5.4	6.6	V	1
				5.6	6.8	V	2, 3
		$V_{Adj} = 3.5V$		2.4	4.6	V	1
				2.8	4.8	V	2, 3
		$V_{Adj} = \text{Open}$		4.878	5.081	V	1
				4.83	5.13	V	2, 3
I_{Adj}	Adjust Current	$V_{Adj} = 2.5V$		-260	260	μA	1
		$V_{Adj} = 1.5V$		-260	260	μA	1
		$V_{Adj} = 3.5V$		-260	260	μA	1
ΔV_R	Reverse Breakdown Change with Current	$0.6\text{mA} \leq I_R \leq 15 \text{ mA}$		-12	12	mV	1
				-20	20	mV	2, 3
V_F	Foward Voltage	$I_R = -10\text{mA}$		-1.5	-0.49	V	1
V_{Stab}	Temperature Stability	$V_R = \text{Adjusted to } 5V$			36	mV	2, 3
Z_{RD}	Reverse Dynamic Impedance		(Note 4)		1.6	Ω	1, 2, 3

LM136A-5.0 Electrical Characteristics

DC Parameters

The following conditions apply, unless otherwise specified. $I_R = 1 \text{ mA}$

Symbol	Parameter	Conditions	Notes	Min	Max	Unit	Sub-groups
V_R	Reverse Breakdown Voltage	$V_{Adj} = 2.5V$		4.6	5.4	V	1
				4.8	5.6	V	2, 3
		$V_{Adj} = 1.5V$		5.4	6.6	V	1
				5.6	6.8	V	2, 3
		$V_{Adj} = 3.5V$		2.4	4.6	V	1
				2.8	4.8	V	2, 3
		$V_{Adj} = \text{Open}$		4.935	5.029	V	1
				4.88	5.08	V	2, 3
I_{Adj}	Adjust Current	$V_{Adj} = 2.5V$		-260	260	μA	1
		$V_{Adj} = 1.5V$		-260	260	μA	1
		$V_{Adj} = 3.5V$		-260	260	μA	1
ΔV_R	Reverse Breakdown Change with Current	$0.6\text{mA} \leq I_R \leq 15 \text{ mA}$		-12	12	mV	1
				-20	20	mV	2, 3
V_F	Foward Voltage	$I_R = -10\text{mA}$		-1.5	-0.49	V	1
V_{Stab}	Temperature Stability	$V_R = \text{Adjusted to } 5V$			36	mV	2, 3
Z_{RD}	Reverse Dynamic Impedance		(Note 4)		1.6	Ω	1, 2, 3

Note 1: Absolute Maximum Ratings indicate limits beyond which damage to the device may occur. Operating Ratings indicate conditions for which the device is functional, but do not guarantee specific performance limits. For guaranteed specifications and test conditions, see the Electrical Characteristics. The guaranteed specifications apply only for the test conditions listed. Some performance characteristics may degrade when the device is not operated under the listed test conditions.

Note 2: The maximum power dissipation must be derated at elevated temperatures and is dictated by T_{Jmax} (maximum junction temperature), θ_{JA} (package junction to ambient thermal resistance), and T_A (ambient temperature). The maximum allowable power dissipation at any temperature is $P_{Dmax} = (T_{Jmax} - T_A) / \theta_{JA}$ or the number given in the Absolute Maximum Ratings, whichever is lower.

Note 3: Human body model, 100pF discharged through 1.5kΩ

Note 4: Guaranteed, not tested.

Typical Performance Characteristics

Reverse Voltage Change

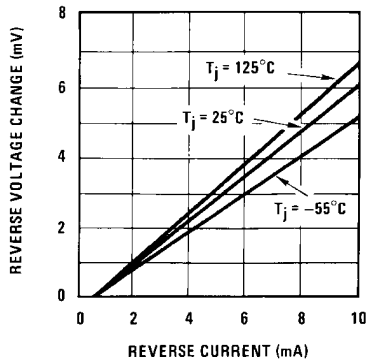

20139817

Zener Noise Voltage

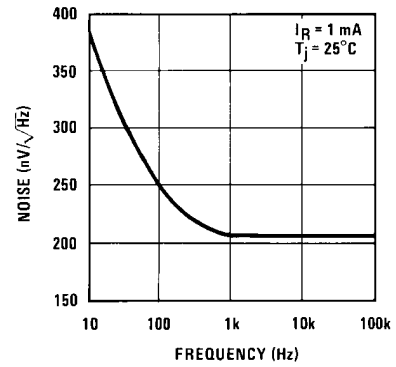

20139818

Dynamic Impedance

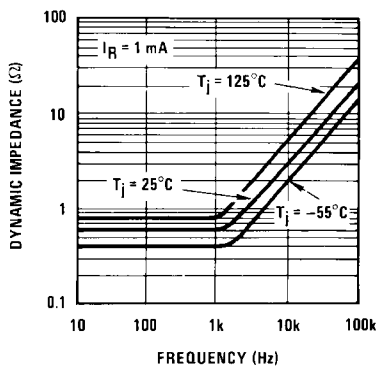

20139819

Response Time

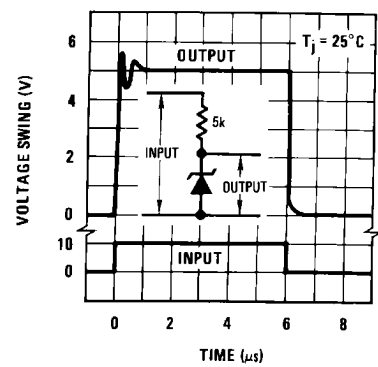

20139820

Reverse Characteristics

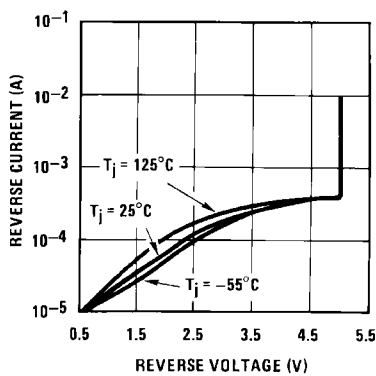

20139821

Temperature Drift

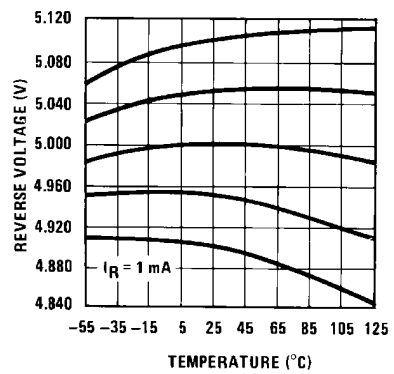

20139822

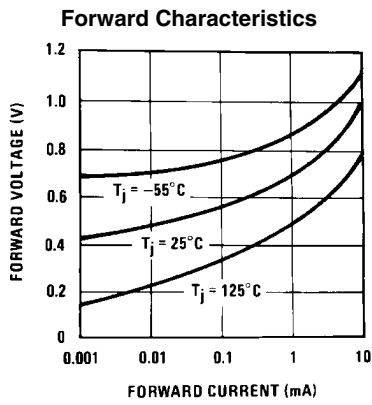

20139823

Application Hints

The LM136-5.0 series voltage references are much easier to use than ordinary zener diodes. Their low impedance and wide operating current range simplify biasing in almost any circuit. Further, either the breakdown voltage or the temperature coefficient can be adjusted to optimize circuit performance.

Figure 1 shows an LM136-5.0 with a 10k potentiometer for adjusting the reverse breakdown voltage. With the addition of R1 the breakdown voltage can be adjusted without affecting the temperature coefficient of the device. The adjustment range is usually sufficient to adjust for both the initial device tolerance and inaccuracies in buffer circuitry.

If minimum temperature coefficient is desired, four diodes can be added in series with the adjustment potentiometer as shown in Figure 2. When the device is adjusted to 5.00V the temperature coefficient is minimized. Almost any silicon signal diode can be used for this purpose such as a 1N914, 1N4148 or a 1N457. For proper temperature compensation the diodes should be in the same thermal environment as the LM136-5.0. It is usually sufficient to mount the diodes near the LM136-5.0 on the printed circuit board. The absolute resistance of the network is not critical and any value from 2k to 20k will work. Because of the wide adjustment range, fixed resistors should be connected in series with the pot to make pot setting less critical.

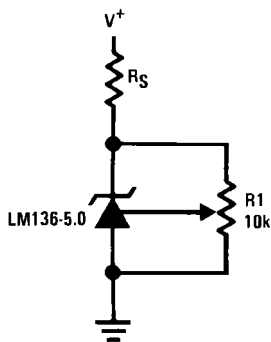

20139809

FIGURE 1. LM136-5.0 with Pot for Adjustment of Breakdown Voltage (Trim Range = ±1.0V Typical)

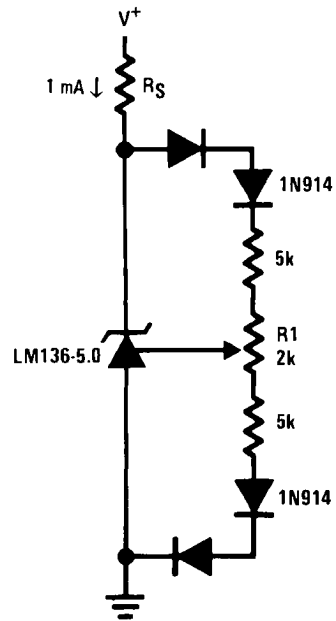

20139810

FIGURE 2. Temperature Coefficient Adjustment (Trim Range = ±0.5V Typical)

Typical Applications

Precision Power Regulator with Low Temperature Coefficient

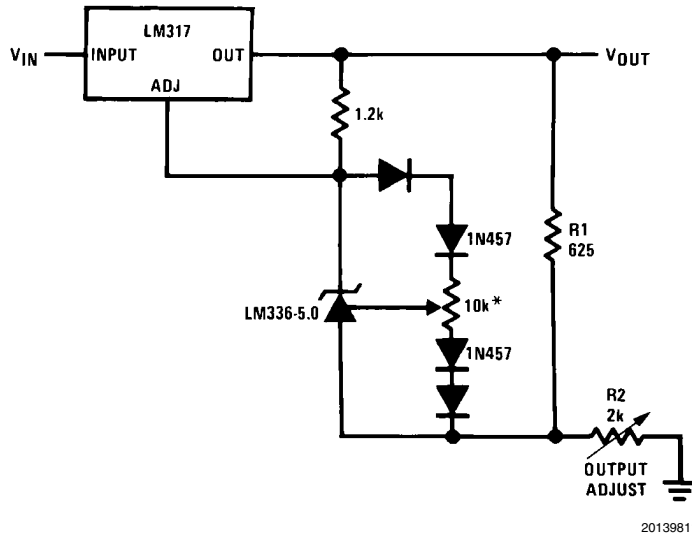

* Adjust for 6.25V across R1

5V Crowbar

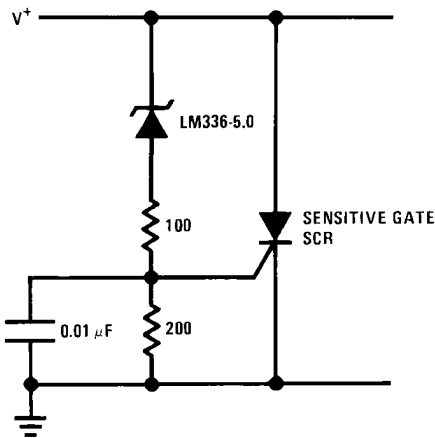

Adjustable Shunt Regulator

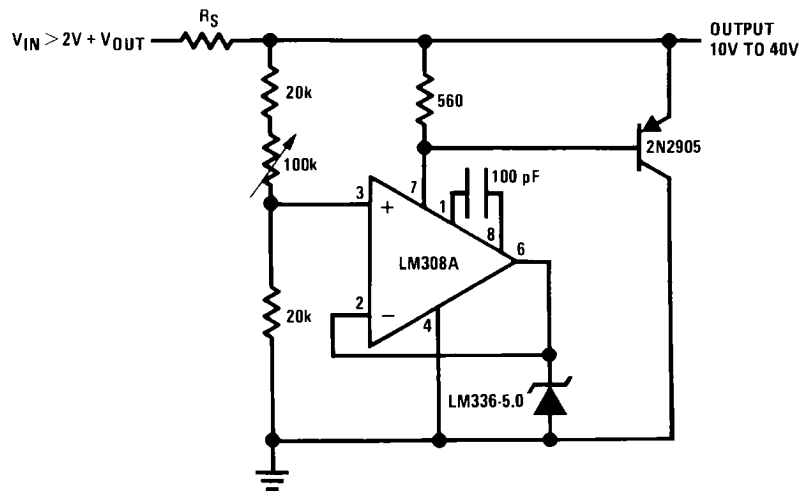

Linear Ohmmeter

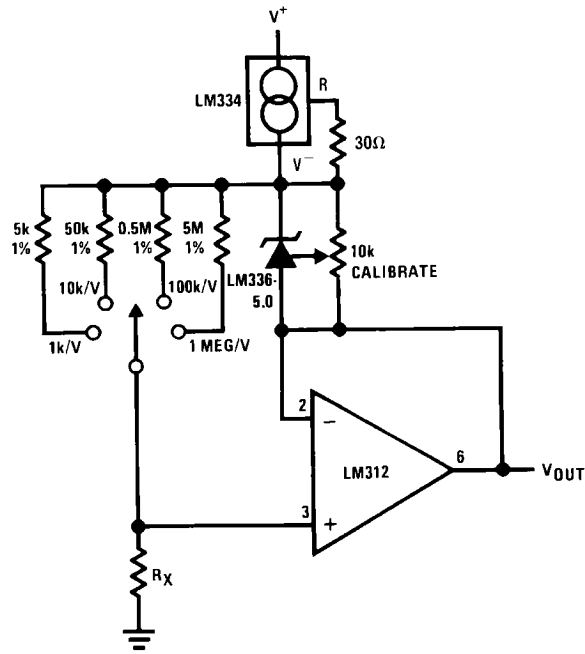

20139814

Op Amp with Output Clamped

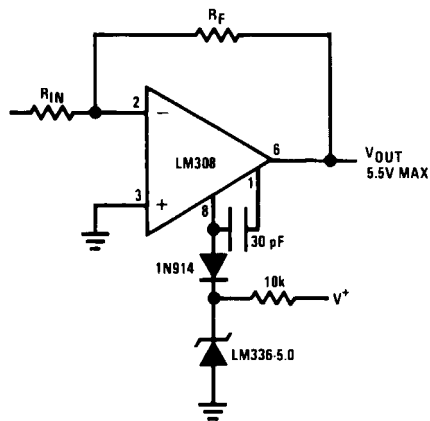

20139824

Bipolar Output Reference

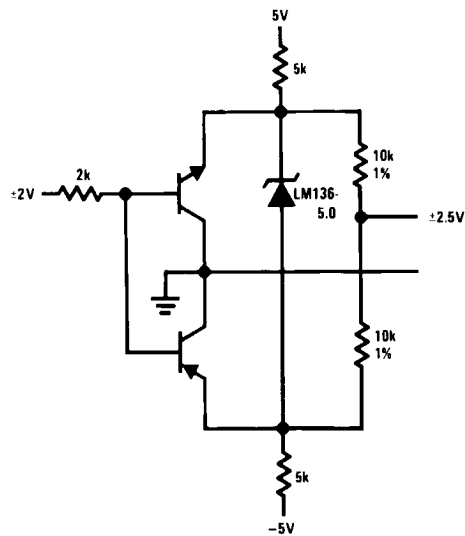

20139825

5.0V Square Wave Calibrator

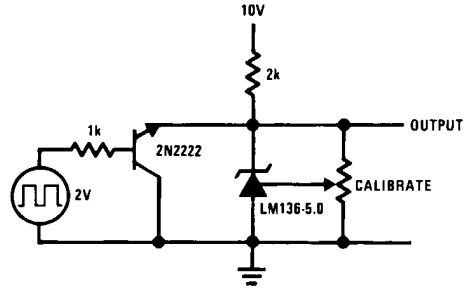

20139826

10V Buffered Reference

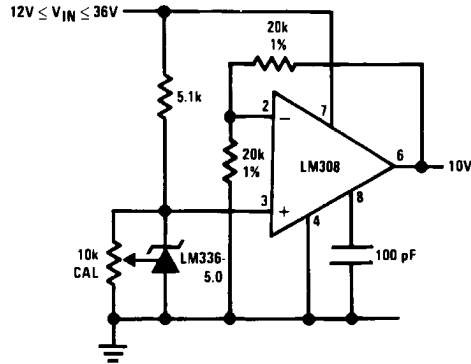

20139827

Low Noise Buffered Reference

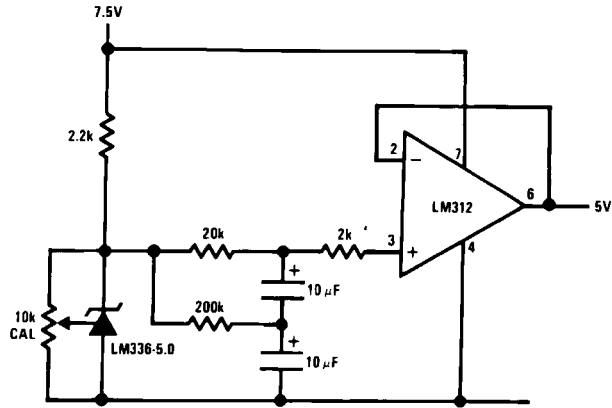

20139828

Wide Input Range Reference

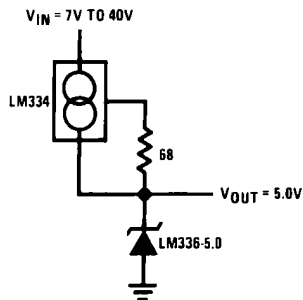

20139829

Revision History

Date Released	Revision	Section	Changes
04/10/08	A	New Release, Corporate format.	2 MDS datasheets were converted into one Corporate datasheet format. MNLM136A-5.0-X Rev 0B0 & LM136-5.0-X Rev 0A0 MDS Data Sheets will be archived.
10/26/2010	B	Data Sheet Title	Changed Title from LM136A-5.0/LM136-5.0QML to LM136A-5.0QML/LM136-5.0QML. Revision A will be Archived.

Physical Dimensions inches (millimeters) unless otherwise noted

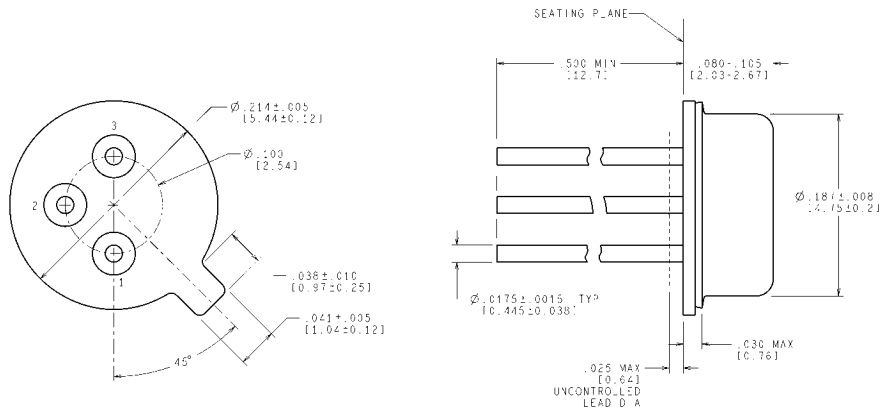

CONTROLLING DIMENSION IS INCH
VALUES IN [] ARE IN MILLIMETERS

H03H (Rev F)

TO-46 Metal Can Package (H)
NS Package Number H03H

Notes

For more National Semiconductor product information and proven design tools, visit the following Web sites at:
www.national.com

Products		Design Support	
Amplifiers	www.national.com/amplifiers	WEBENCH® Tools	www.national.com/webench
Audio	www.national.com/audio	App Notes	www.national.com/appnotes
Clock and Timing	www.national.com/timing	Reference Designs	www.national.com/refdesigns
Data Converters	www.national.com/adc	Samples	www.national.com/samples
Interface	www.national.com/interface	Eval Boards	www.national.com/evalboards
LVDS	www.national.com/lvds	Packaging	www.national.com/packaging
Power Management	www.national.com/power	Green Compliance	www.national.com/quality/green
Switching Regulators	www.national.com/switchers	Distributors	www.national.com/contacts
LDOs	www.national.com/ldo	Quality and Reliability	www.national.com/quality
LED Lighting	www.national.com/led	Feedback/Support	www.national.com/feedback
Voltage References	www.national.com/vref	Design Made Easy	www.national.com/easy
PowerWise® Solutions	www.national.com/powerwise	Applications & Markets	www.national.com/solutions
Serial Digital Interface (SDI)	www.national.com/sdi	Mil/Aero	www.national.com/milaero
Temperature Sensors	www.national.com/tempensors	SolarMagic™	www.national.com/solarmagic
PLL/VCO	www.national.com/wireless	PowerWise® Design University	www.national.com/training

THE CONTENTS OF THIS DOCUMENT ARE PROVIDED IN CONNECTION WITH NATIONAL SEMICONDUCTOR CORPORATION ("NATIONAL") PRODUCTS. NATIONAL MAKES NO REPRESENTATIONS OR WARRANTIES WITH RESPECT TO THE ACCURACY OR COMPLETENESS OF THE CONTENTS OF THIS PUBLICATION AND RESERVES THE RIGHT TO MAKE CHANGES TO SPECIFICATIONS AND PRODUCT DESCRIPTIONS AT ANY TIME WITHOUT NOTICE. NO LICENSE, WHETHER EXPRESS, IMPLIED, ARISING BY ESTOPPEL OR OTHERWISE, TO ANY INTELLECTUAL PROPERTY RIGHTS IS GRANTED BY THIS DOCUMENT.

TESTING AND OTHER QUALITY CONTROLS ARE USED TO THE EXTENT NATIONAL DEEMS NECESSARY TO SUPPORT NATIONAL'S PRODUCT WARRANTY. EXCEPT WHERE MANDATED BY GOVERNMENT REQUIREMENTS, TESTING OF ALL PARAMETERS OF EACH PRODUCT IS NOT NECESSARILY PERFORMED. NATIONAL ASSUMES NO LIABILITY FOR APPLICATIONS ASSISTANCE OR BUYER PRODUCT DESIGN. BUYERS ARE RESPONSIBLE FOR THEIR PRODUCTS AND APPLICATIONS USING NATIONAL COMPONENTS. PRIOR TO USING OR DISTRIBUTING ANY PRODUCTS THAT INCLUDE NATIONAL COMPONENTS, BUYERS SHOULD PROVIDE ADEQUATE DESIGN, TESTING AND OPERATING SAFEGUARDS.

EXCEPT AS PROVIDED IN NATIONAL'S TERMS AND CONDITIONS OF SALE FOR SUCH PRODUCTS, NATIONAL ASSUMES NO LIABILITY WHATSOEVER, AND NATIONAL DISCLAIMS ANY EXPRESS OR IMPLIED WARRANTY RELATING TO THE SALE AND/OR USE OF NATIONAL PRODUCTS INCLUDING LIABILITY OR WARRANTIES RELATING TO FITNESS FOR A PARTICULAR PURPOSE, MERCHANTABILITY, OR INFRINGEMENT OF ANY PATENT, COPYRIGHT OR OTHER INTELLECTUAL PROPERTY RIGHT.

LIFE SUPPORT POLICY

NATIONAL'S PRODUCTS ARE NOT AUTHORIZED FOR USE AS CRITICAL COMPONENTS IN LIFE SUPPORT DEVICES OR SYSTEMS WITHOUT THE EXPRESS PRIOR WRITTEN APPROVAL OF THE CHIEF EXECUTIVE OFFICER AND GENERAL COUNSEL OF NATIONAL SEMICONDUCTOR CORPORATION. As used herein:

Life support devices or systems are devices which (a) are intended for surgical implant into the body, or (b) support or sustain life and whose failure to perform when properly used in accordance with instructions for use provided in the labeling can be reasonably expected to result in a significant injury to the user. A critical component is any component in a life support device or system whose failure to perform can be reasonably expected to cause the failure of the life support device or system or to affect its safety or effectiveness.

National Semiconductor and the National Semiconductor logo are registered trademarks of National Semiconductor Corporation. All other brand or product names may be trademarks or registered trademarks of their respective holders.

Copyright© 2010 National Semiconductor Corporation

For the most current product information visit us at www.national.com



**National Semiconductor
Americas Technical
Support Center**
Email: support@nsc.com
Tel: 1-800-272-9959

**National Semiconductor Europe
Technical Support Center**
Email: europe.support@nsc.com

**National Semiconductor Asia
Pacific Technical Support Center**
Email: ap.support@nsc.com

**National Semiconductor Japan
Technical Support Center**
Email: jpn.feedback@nsc.com