

National Semiconductor is now part of
Texas Instruments.

Search <http://www.ti.com/> for the latest technical
information and details on our current products and services.



NATL SEMICON (LINEAR)

T-73-53

LM161/LM261/LM361

High Speed Differential Comparators

General Description

The LM161/LM261/LM361 is a very high speed differential input, complementary TTL output voltage comparator with improved characteristics over the SE529/NE529 for which it is a pin-for-pin replacement. The device has been optimized for greater speed performance and lower input offset voltage. Typically delay varies only 3 ns for over-drive variations of 5 mV to 500 mV. It may be operated from op amp supplies ($\pm 15V$).

Complementary outputs having maximum skew are provided. Applications involve high speed analog to digital converters and zero-crossing detectors in disk file systems.

Features

- Independent strobes
- Guaranteed high speed 20 ns max
- Tight delay matching on both outputs
- Complementary TTL outputs
- Operates from op amp supplies $\pm 15V$
- Low speed variation with overdrive variation
- Low input offset voltage
- Versatile supply voltage range

Connection Diagrams

Dual-In-Line Package

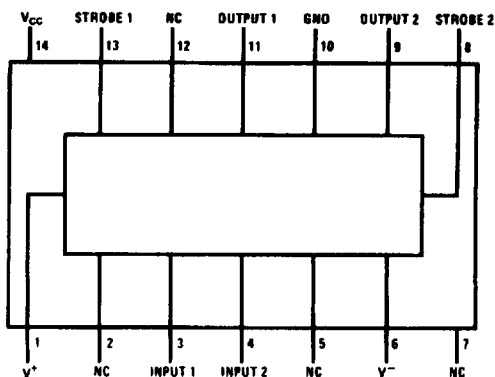

TL/H/5708-2

Top View

Order Number LM161J, LM161J/883*, LM361J,
LM361M or LM361N

See NS Package Number J14A, M14A or N14A

*Also available per SMD #5962-8757203

Metal Can Package

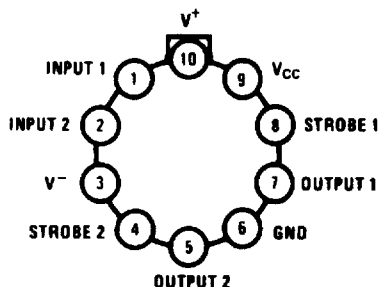

TL/H/5708-3

Order Number LM161H, LM161H/883*,
LM261H or LM361H
See NS Package Number H10C

Logic Diagram

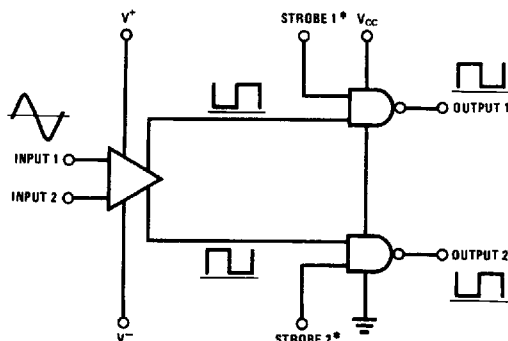

*Output is low when current is drawn from strobe pin.

TL/H/5708-4

Absolute Maximum Ratings (Note 1)

If Military/Aerospace specified devices are required, please contact the National Semiconductor Sales Office/Distributors for availability and specifications. (Note 4)

Positive Supply Voltage, V^+	+16V
Negative Supply Voltage, V^-	-16V
Gate Supply Voltage, V_{CC}	+7V
Output Voltage	+7V
Differential Input Voltage	±5V
Input Common Mode Voltage	±6V
Power Dissipation	600 mW
Storage Temperature Range	-65°C to +150°C
Operating Temperature Range	T_{MIN} T_{MAX}
LM161	-55°C to +125°C
LM261	-25°C to +85°C
LM361	0°C to +70°C
Lead Temp. (Soldering, 10 seconds)	260°C
For Any Device Lead Below V^-	0.3V

Operating Conditions

	Min	Typ	Max
Supply Voltage V^+			
LM161/LM261	5V		15V
LM361	5V		15V
Supply Voltage V^-			
LM161/LM261	-6V		-15V
LM361	-6V		-15V
Supply Voltage V_{CC}			
LM161/LM261	4.5V	5V	5.5V
LM361	4.75V	5V	5.25V
ESD Tolerance (Note 5)			1600V
Soldering Information			
Dual-In-Line Package			
Soldering (10 seconds)			260°C
Small Outline Package			
Vapor Phase (60 seconds)			215°C
Infrared (15 seconds)			220°C
See AN-450 "Surface Mounting Methods and Their Effect on Product Reliability" for other methods of soldering surface mount devices.			

Electrical Characteristics ($V^+ = +10V$, $V_{CC} = +5V$, $V^- = -10V$, $T_{MIN} \leq T_A \leq T_{MAX}$, unless noted)

Parameter	Conditions	Limits						Units
		LM161/LM261			LM361			
		Min	Typ	Max	Min	Typ	Max	
Input Offset Voltage			1	3		1	5	mV
Input Bias Current	$T_A = 25^\circ\text{C}$		5	20		10	30	μA μA
Input Offset Current	$T_A = 25^\circ\text{C}$		2	3		2	5	μA μA
Voltage Gain	$T_A = 25^\circ\text{C}$		3			3		V/mV
Input Resistance	$T_A = 25^\circ\text{C}$, $f = 1\text{ kHz}$		20			20		k Ω
Logical "1" Output Voltage	$V_{CC} = 4.75V$, $I_{SOURCE} = -0.5\text{ mA}$	2.4	3.3		2.4	3.3		V
Logical "0" Output Voltage	$V_{CC} = 4.75V$, $I_{SINK} = 6.4\text{ mA}$			0.4			0.4	V
Strobe Input "1" Current (Output Enabled)	$V_{CC} = 5.25V$, $V_{STROBE} = 2.4V$			200			200	μA
Strobe Input "0" Current (Output Disabled)	$V_{CC} = 5.25V$, $V_{STROBE} = 0.4V$			-1.6			-1.6	mA
Strobe Input "0" Voltage	$V_{CC} = 4.75V$			0.8			0.8	V
Strobe Input "1" Voltage	$V_{CC} = 4.75V$	2			2			V
Output Short Circuit Current	$V_{CC} = 5.25V$, $V_{OUT} = 0V$	-18		-55	-18		-55	mA

Electrical Characteristics (Continued)

NATL SEMICON (LINEAR)

 $(V^+ = +10V, V_{CC} = +5V, V^- = -10V, T_{MIN} \leq T_A \leq T_{MAX}, \text{ unless noted})$

Parameter	Conditions	Limits						Units
		LM161/LM261			LM361			
		Min	Typ	Max	Min	Typ	Max	
Supply Current I^+	$V^+ = 10V, V^- = -10V,$ $V_{CC} = 5.25V,$ $-55^\circ C \leq T_A \leq 125^\circ C$			4.5				mA
Supply Current I^+	$V^+ = 10V, V^- = -10V,$ $V_{CC} = 5.25V,$ $0^\circ C \leq T_A \leq 70^\circ C$						5	mA
Supply Current I^-	$V^+ = 10V, V^- = -10V,$ $V_{CC} = 5.25V,$ $-55^\circ C \leq T_A \leq 125^\circ C$			10				mA
Supply Current I^-	$V^+ = 10V, V^- = -10V,$ $V_{CC} = 5.25V,$ $0^\circ C \leq T_A \leq 70^\circ C$						10	mA
Supply Current I_{CC}	$V^+ = 10V, V^- = -10V,$ $V_{CC} = 5.25V,$ $-55^\circ C \leq T_A \leq 125^\circ C$			18				mA
Supply Current I_{CC}	$V^+ = 10V, V^- = -10V,$ $V_{CC} = 5.25V,$ $0^\circ C \leq T_A \leq 70^\circ C$						20	mA
Transient Response	$V_{IN} = 50 \text{ mV overdrive}$ (Note 3)							
Propagation Delay Time ($t_{pd(0)}$)	$T_A = 25^\circ C$		14	20		14	20	ns
Propagation Delay Time ($t_{pd(1)}$)	$T_A = 25^\circ C$		14	20		14	20	ns
Delay Between Output A and B	$T_A = 25^\circ C$		2	5		2	5	ns
Strobe Delay Time ($t_{pd(0)}$)	$T_A = 25^\circ C$		8			8		ns
Strobe Delay Time ($t_{pd(1)}$)	$T_A = 25^\circ C$		8			8		ns

Note 1: The device may be damaged by use beyond the maximum ratings.**Note 2:** Typical thermal impedances are as follows:

	H Package	J Package	N Package
θ_{JA}	165°C/W (Still Air) 67°C/W (400 LF/Min Air Flow)	112°C/W	105°C/W
θ_{JC}	25°C/W		

Note 3: Measurements using AC Test circuit, Fanout = 1. The devices are faster at low supply voltages.**Note 4:** Refer to RETS161X for LM161H and LM161J military specifications.**Note 5:** Human body model, 1.5 k Ω in series with 100 pF.

Typical Performance Characteristics

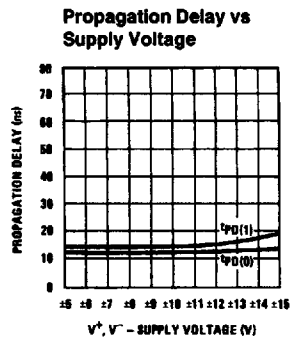
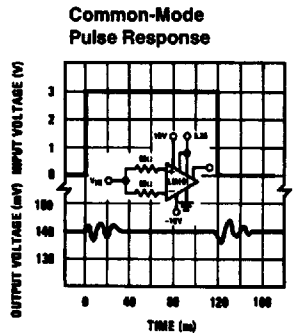
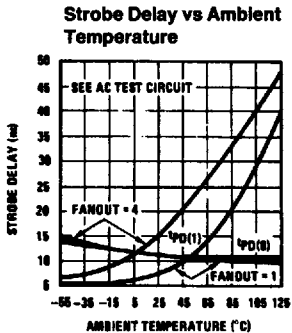
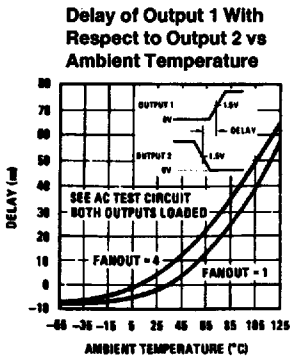
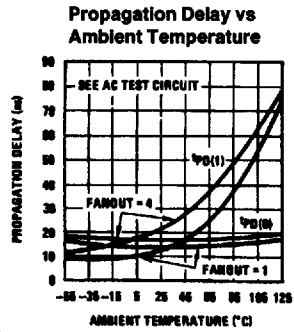
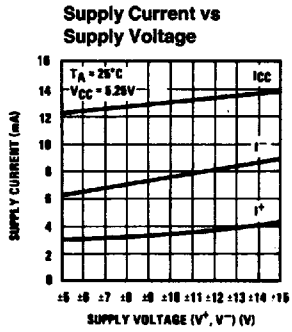
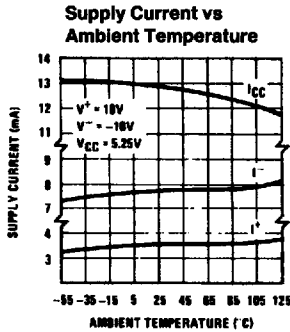
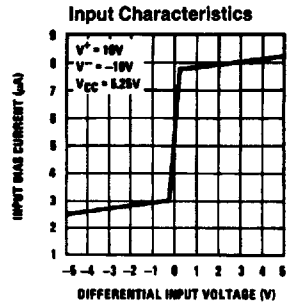
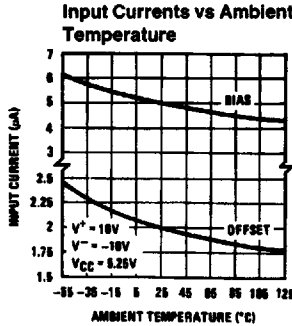
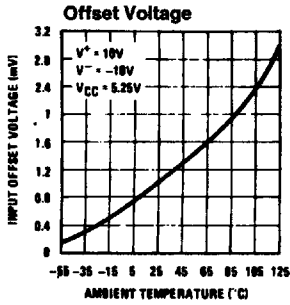

AC Test Circuit

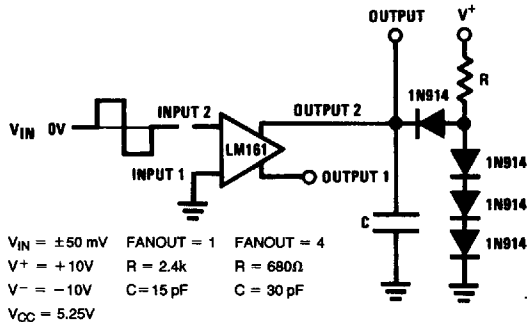

$V_{IN} = \pm 50 \text{ mV}$ FANOUT = 1 FANOUT = 4
 $V^+ = +10V$ $R = 2.4k$ $R = 680\Omega$
 $V^- = -10V$ $C = 15 \text{ pF}$ $C = 30 \text{ pF}$
 $V_{CC} = 5.25V$

TL/H/5708-5

TL/H/5708-6

LM161/LM261/LM361

NATL SEMICOND (LINEAR)

Schematic Diagram

LM161

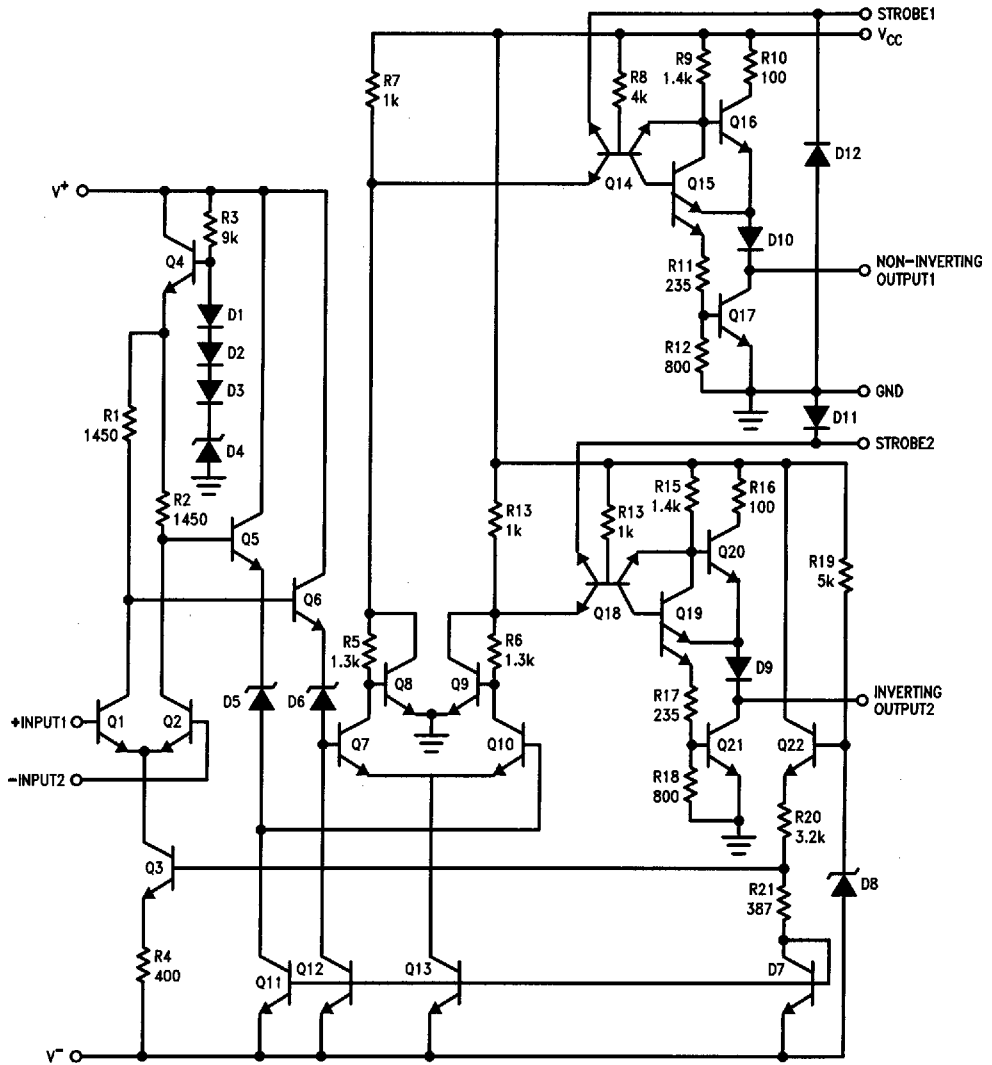

R10, R16: 85
R11, R17: 205

TL/H/5708-1