

# LINEAR INTEGRATED CIRCUITS

# CIRCUIT TYPES SN52702A, SN52702, SN72702 GENERAL-PURPOSE OPERATIONAL AMPLIFIERS

### SN52702A features

- Open-Loop Voltage Amplification . . . 3600 Typ
- Designed to be Interchangeable With Fairchild  $\mu$ A702A
- CMRR . . . 100 dB Typ

### description

The SN52702A, SN52702 and SN72702 circuits are high-gain, wideband operational amplifiers, each having differential inputs and single-ended emitter-follower outputs. Provisions are incorporated within the circuit whereby external components may be used to compensate the amplifier for stable operation under various feedback or load conditions. Component matching, inherent in silicon monolithic circuit-fabrication techniques, produces an amplifier with low-drift and low-offset characteristics. The SN52702A is an improved version of the SN52702. These amplifiers are particularly useful for applications requiring transfer or generation of linear and non-linear functions up to a frequency of 30 MHz.

The SN52702A and SN52702 circuits are characterized for operation over the full military temperature range of  $-55^{\circ}\text{C}$  to  $125^{\circ}\text{C}$ . The SN72702 circuit is characterized for operation over the temperature range of  $0^{\circ}\text{C}$  to  $70^{\circ}\text{C}$ .

### schematic

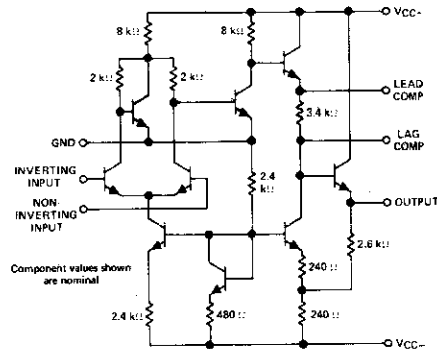

3

### terminal assignments

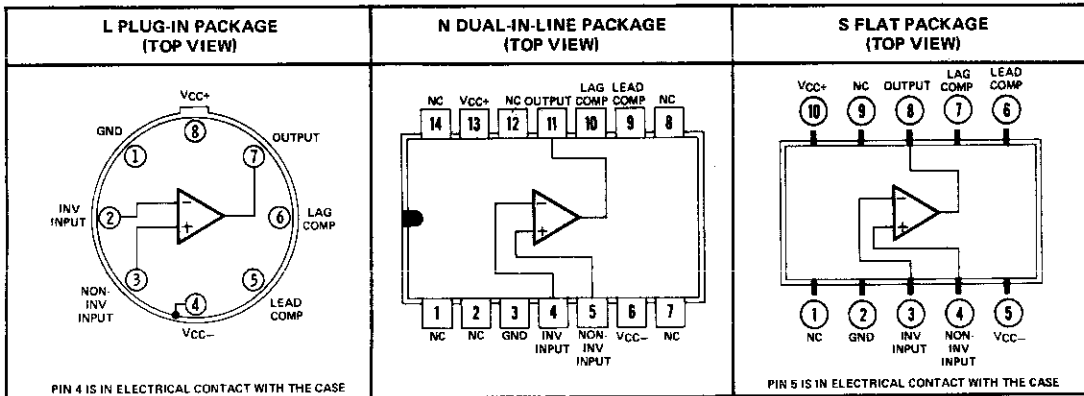

NC—No internal connection

### absolute maximum ratings over operating free-air temperature (unless otherwise noted)

	SN52702A, SN52702	SN72702	UNIT
Supply voltage $V_{CC+}$ (see Note 1)	14	14	V
Supply voltage $V_{CC-}$ (see Note 1)	-7	-7	V
Differential input voltage (see Note 2)	$\pm 5$	$\pm 5$	V
Input voltage (either input, see Notes 1 and 3)	-6 to 1.5	-6 to 1.5	V
Peak output current ( $t_w \leq 1$ S)	50	50	mA
Continuous total dissipation at (or below) $70^{\circ}\text{C}$ free-air temperature (see Note 4)	300	300	mW
Operating free-air temperature range	-55 to 125	0 to 70	$^{\circ}\text{C}$
Storage temperature range	-65 to 150	-65 to 150	$^{\circ}\text{C}$
Lead temperature 1/16 inch from case for 60 seconds	L or S Package		300 $^{\circ}\text{C}$
Lead temperature 1/16 inch from case for 10 seconds	N Package		260 $^{\circ}\text{C}$

- NOTES: 1. All voltage values, unless otherwise noted, are with respect to the network ground terminal.  
 2. Differential voltages are at the noninverting input terminal with respect to the inverting input terminal.  
 3. The magnitude of the input voltage must never exceed the magnitude of the lesser of the two supply voltages.  
 4. For operation of SN52702A and SN52702 above  $70^{\circ}\text{C}$  free-air temperature, refer to Dissipation Derating Curve, Figure 3.

# CIRCUIT TYPES SN52702A, SN52702, SN72702 GENERAL-PURPOSE OPERATIONAL AMPLIFIERS

## SN52702A

electrical characteristics at specified free-air temperature

PARAMETER	TEST CONDITIONS†	SN52702A						UNIT		
		V <sub>CC+</sub> = 12 V V <sub>CC-</sub> = -6 V			V <sub>CC+</sub> = 6 V V <sub>CC-</sub> = -3 V					
		MIN	TYP	MAX	MIN	TYP	MAX			
V <sub>IO</sub>	Input offset voltage R <sub>S</sub> ≤ 2 kΩ	25°C	0.5	2	0.7	3	mV			
		Full range	3			4				
α <sub>VIO</sub>	Average temperature coefficient of input offset voltage R <sub>S</sub> = 50 Ω	-55°C to 25°C	2	10	3	15	μV/°C			
		25°C to 125°C	2.5	10	3.5	15				
I <sub>IO</sub>	Input offset current	25°C	0.2	0.5	0.12	0.5	μA			
		-55°C	0.4	1.5	0.3	1.5				
		125°C	0.08	0.5	0.05	0.5				
α <sub>IIO</sub>	Average temperature coefficient of input offset current	-55°C to 25°C	3	16	2	13	nA/°C			
		25°C to 125°C	1	5	0.7	4				
I <sub>IB</sub>	Input bias current	25°C	2	5	1.2	3.5	μA			
		-55°C	4.3	10	2.6	7.5				
V <sub>I</sub>	Positive swing	25°C	0.5	1	0.5	1	V			
	Negative swing		-4	-5	-1.5	-2				
V <sub>OPP</sub>	Maximum peak-to-peak output voltage swing	R <sub>L</sub> ≥ 100 kΩ	25°C	10	10.6	5	5.4	V		
		R <sub>L</sub> = 10 kΩ	Full range	10			5			
			25°C	7	8	3	4			
			Full range	7			3			
A <sub>VD</sub>	Large-signal differential voltage amplification R <sub>L</sub> ≥ 100 kΩ	V <sub>O</sub> = ±5 V	25°C	2500	3600	6000				
			Full range	2000	7000					
		V <sub>O</sub> = ±2.5 V	25°C					600	900	1500
			Full range					500	1750	
r <sub>i</sub>	Input resistance	25°C	16	40	22	67	kΩ			
		Full range	6			8				
r <sub>o</sub>	Output resistance V <sub>O</sub> = 0, See Note 3	25°C	200	500	300	700	Ω			
CMRR	Common-mode rejection ratio R <sub>S</sub> ≤ 2 kΩ	25°C	80	100	80	100	dB			
		Full range	70			70				
ΔV <sub>IO</sub> /ΔV <sub>CC</sub>	Power supply sensitivity R <sub>S</sub> ≤ 2 kΩ	25°C	75		75		μV/V			
		Full range	200		200					
I <sub>CC</sub>	Supply current No load, No signal	25°C	5	6.7	2.1	3.3	mA			
		-55°C	5	7.5	2.1	3.9				
		125°C	4.4	6.7	1.7	3.3				
P <sub>D</sub>	Total power dissipation No load, No signal	25°C	90	120	19	30	mW			
		-55°C	90	135	19	35				
		125°C	80	120	15	30				

3

† All characteristics are specified under open-loop operation. Full range for SN52702A is -55°C to 125°C.

NOTE 3: This typical value applies only at frequencies above a few hundred hertz because of the effects of drift and thermal feedback.

# CIRCUIT TYPES SN52702A, SN52702, SN72702

## GENERAL-PURPOSE OPERATIONAL AMPLIFIERS

### SN52702

electrical characteristics at specified free-air temperature

PARAMETER	TEST CONDITIONS†		SN52702						UNIT				
			V <sub>CC+</sub> = 12 V			V <sub>CC+</sub> = 6 V							
			V <sub>CC-</sub> = -6 V			V <sub>CC-</sub> = -3 V							
			MIN	TYP	MAX	MIN	TYP	MAX					
V <sub>IO</sub>	Input offset voltage	R <sub>S</sub> ≤ 2 kΩ	25°C	2	5		2	5		mV			
			Full range			6			6				
α <sub>VIO</sub>	Average temperature coefficient of input offset voltage	R <sub>S</sub> = 50 Ω	-55°C to 25°C	10			10			μV/°C			
			25°C to 125°C	5			5						
I <sub>IO</sub>	Input offset current		25°C	0.5		2		0.3		2			
			-55°C	1		3		3		3			
			125°C	0.2		3		3		3			
α <sub>IIO</sub>	Average temperature coefficient of input offset current		-55°C to 25°C	6			5			nA/°C			
			25°C to 125°C	3			2						
I <sub>IB</sub>	Input bias current		25°C	4		10		2.5		7			
			-55°C	6.5		20		14		14			
V <sub>I</sub>	Input voltage range		25°C	Positive swing		0.5		1		0.5		1	
				Negative swing		-4		-5		-1.5		-2	
V <sub>OPP</sub>	Maximum peak-to-peak output voltage swing	R <sub>L</sub> ≥ 100 kΩ		10		10.6		5		5.4		V	
		R <sub>L</sub> = 10 kΩ		8		4		4		4			
A <sub>VD</sub>	Large-signal differential voltage amplification	R <sub>L</sub> ≥ 100 kΩ	V <sub>O</sub> = ±5 V	25°C	1400		2600						
				Full range	1000								
			V <sub>O</sub> = ±2.5 V	25°C			380		700				
r <sub>i</sub>	Input resistance		25°C	8		25		12		40		kΩ	
			Full range	3		4							
r <sub>o</sub>	Output resistance	V <sub>O</sub> = 0, See Note 3	25°C	200		500		300		700		Ω	
CMRR	Common-mode rejection ratio	R <sub>S</sub> ≤ 2 kΩ	25°C	70		80		70		80		dB	
ΔV <sub>IO</sub> /ΔV <sub>CC</sub>	Power supply sensitivity	R <sub>S</sub> ≤ 2 kΩ	25°C	60		300		60		300		μV/V	
I <sub>CC</sub>	Supply current	No load, No signal	25°C	5		6.7		2.1		3.9		mA	
P <sub>D</sub>	Total power dissipation	No load, No signal	25°C	90		120		19		35		mW	

† All characteristics are specified under open-loop operation. Full range for SN52702 is -55°C to 125°C.

NOTE 3: This typical value applies only at frequencies above a few hundred hertz because of the effects of drift and thermal feedback.

## CIRCUIT TYPES SN52702A, SN52702, SN72702 GENERAL-PURPOSE OPERATIONAL AMPLIFIERS

### SN72702

electrical characteristics at specified free-air temperature,  $V_{CC+} = 12\text{ V}$ ,  $V_{CC-} = -6\text{ V}$

PARAMETER	TEST CONDITIONS†	SN72702			UNIT
		MIN	TYP	MAX	
$V_{IO}$ Input offset voltage	$R_S \leq 2\text{ k}\Omega$		5	10	mV
			Full Range 15		
$\alpha V_{IO}$ Average temperature coefficient of input offset voltage	$R_S = 50\ \Omega$		5		$\mu\text{V}/^\circ\text{C}$
$I_{IO}$ Input offset current			0.5	5	$\mu\text{A}$
			Full Range 7.5		
$\alpha I_{IO}$ Average temperature coefficient of input offset current			5		$\text{nA}/^\circ\text{C}$
			0°C to 25°C 25°C to 70°C 3		
$I_{IB}$ Input bias current			4	15	$\mu\text{A}$
			0°C 4.5 20		
$V_I$ Input voltage range	Positive swing Negative swing	25°C	0.5 -4	1 -5	V
$V_{OPP}$ Maximum peak-to-peak output voltage swing	$R_L \geq 100\text{ k}\Omega$	25°C	10	10.6	V
$A_{VD}$ Large-signal differential voltage amplification	$R_L \geq 100\text{ k}\Omega$ , $V_O = \pm 5\text{ V}$	25°C	1000	2600	
			Full Range 800		
$r_i$ Input resistance		25°C	6	25	$\text{k}\Omega$
			Full Range 3.5		
$r_o$ Output resistance	$V_O = 0$ , See Note 3	25°C	200	600	$\Omega$
CMRR Common-mode rejection ratio	$R_S \leq 2\text{ k}\Omega$	25°C	65	80	dB
$\Delta V_{IO}/\Delta V_{CC}$ Power supply sensitivity	$R_S \leq 2\text{ k}\Omega$	25°C	60	300	$\mu\text{V}/\text{V}$
$I_{CC}$ Supply current	No load, No signal	25°C	5	7	mA
$P_D$ Total power dissipation	No load, No signal	25°C	90	125	mW

3

† All characteristics are specified under open-loop operation. Full range for SN72702 is 0°C to 70°C.  
NOTE 3: This typical value applies only at frequencies above a few hundred hertz because of the effects of drift and thermal feedback.

### SN52702A, SN52702, SN72702

operating characteristics  $V_{CC+} = 12\text{ V}$ ,  $V_{CC-} = -6\text{ V}$ ,  $T_A = 25^\circ\text{C}$

PARAMETER	TEST FIGURE	TEST CONDITIONS	ALL TYPES			UNIT
			MIN	TYP	MAX	
$t_r$ Rise time	1	$V_I = 10\text{ mV}$ , $C_L = 0$	25	120		ns
	2	$V_I = 1\text{ mV}$	10	30		
Overshoot	1	$V_I = 10\text{ mV}$ , $C_L = 100\text{ pF}$	10%	50%		
	2	$V_I = 1\text{ mV}$	20%	40%		
SR Slew rate	1	$V_I = 6\text{ V}$ , $C_L = 100\text{ pF}$	1.7			$\text{V}/\mu\text{s}$
	2	$V_I = 100\text{ mV}$	11			

# CIRCUIT TYPES SN52702A, SN52702, SN72702 GENERAL-PURPOSE OPERATIONAL AMPLIFIERS

## PARAMETER MEASUREMENT INFORMATION

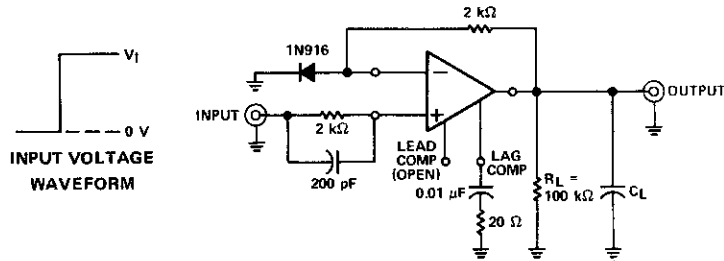

FIGURE 1—UNITY-GAIN AMPLIFIER

3

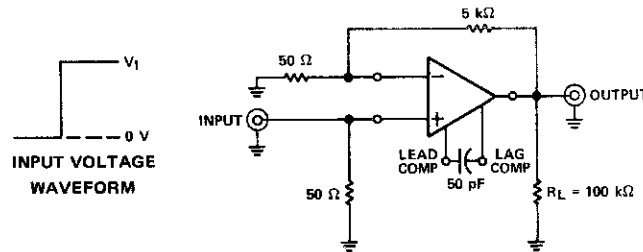

FIGURE 2—GAIN-OF-100 AMPLIFIER

## THERMAL INFORMATION

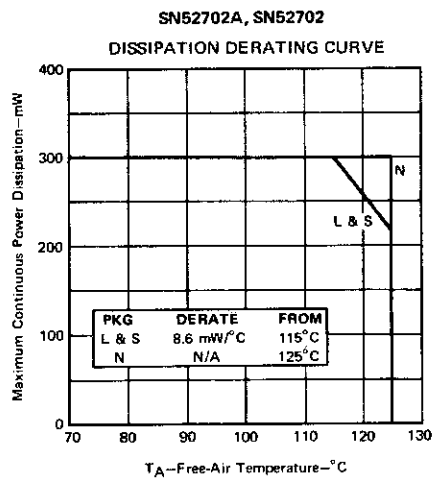

FIGURE 3

# CIRCUIT TYPES SN52702A, SN52702, SN72702

## GENERAL-PURPOSE OPERATIONAL AMPLIFIERS

---

### DEFINITION OF TERMS

**Input Offset Voltage ( $V_{IO}$ )** The d-c voltage which must be applied between the input terminals to force the quiescent d-c output voltage to zero. The input offset voltage may also be defined for the case where two equal resistances ( $R_G$ ) are inserted in series with the input leads.

**Average Temperature Coefficient of Input Offset Voltage ( $\alpha_{VIO}$ )** The ratio of the change in input offset voltage to the change in free-air temperature. This is an average value for the specified temperature range.

$$\alpha_{VIO} = \left| \frac{(V_{IO} @ T_{A(1)}) - (V_{IO} @ T_{A(2)})}{T_{A(1)} - T_{A(2)}} \right| \text{ where } T_{A(1)} \text{ and } T_{A(2)} \text{ are the specified temperature extremes.}$$

**Input Offset Current ( $I_{IO}$ )** The difference between the currents into the two input terminals with the output at zero volts.

**Average Temperature Coefficient Of Input Offset Current ( $\alpha_{IIO}$ )** The ratio of the change in input offset current to the change in free-air temperature. This is an average value for the specified temperature range.

$$\alpha_{IIO} = \left| \frac{(I_{IO} @ T_{A(1)}) - (I_{IO} @ T_{A(2)})}{T_{A(1)} - T_{A(2)}} \right| \text{ where } T_{A(1)} \text{ and } T_{A(2)} \text{ are the specified temperature extremes.}$$

3

**Input Bias Current ( $I_{IB}$ )** The average of the currents into the two input terminals with the output at zero volts.

**Input Voltage Range ( $V_I$ )** The range of voltage which if exceeded at either input terminal will cause the amplifier to cease functioning properly.

**Maximum Peak-to-Peak Output Voltage Swing ( $V_{OPP}$ )** The maximum peak-to-peak output voltage which can be obtained without waveform clipping when the quiescent d-c output voltage is zero.

**Large-Signal Differential Voltage Amplification ( $A_{VD}$ )** The ratio of the peak-to-peak output voltage swing to the change in differential input voltage required to drive the output.

**Input Resistance ( $r_i$ )** The resistance between the input terminals with either input grounded.

**Output Resistance ( $r_o$ )** The resistance between the output terminal and ground.

**Common-Mode Rejection Ratio (CMRR)** The ratio of differential voltage amplification to common-mode voltage amplification. This is measured by determining the ratio of a change in input common-mode voltage to the resulting change in input offset voltage.

**Power Supply Sensitivity ( $\Delta V_{IO}/\Delta V_{CC}$ )** The ratio of the change in input offset voltage to the change in supply voltages producing it. For these devices, both supply voltages are varied symmetrically.

**Total Power Dissipation ( $P_D$ )** The total d-c power supplied to the device less any power delivered from the device to a load. At no load:  $P_D = V_{CC+} \cdot I_{CC+} + V_{CC-} \cdot I_{CC-}$ .

**Rise Time ( $t_r$ )** The time required for an output voltage step to change from 10% to 90% of its final value.

**Overshoot** The quotient of: (1) the largest deviation of the output signal value from its steady-state value after a step-function change of the input signal, and (2) the difference between the output signal values in the steady state before and after the step-function change of the input signal.

**Slew Rate (SR)** The average time rate of change of the closed-loop amplifier output voltage for a step-signal input. Slew rate is measured between specified output levels (0 and 10 volts for this device) with feedback adjusted for unity gain.

# CIRCUIT TYPES SN52702A, SN52702, SN72702 GENERAL-PURPOSE OPERATIONAL AMPLIFIERS

## TYPICAL CHARACTERISTICS

3

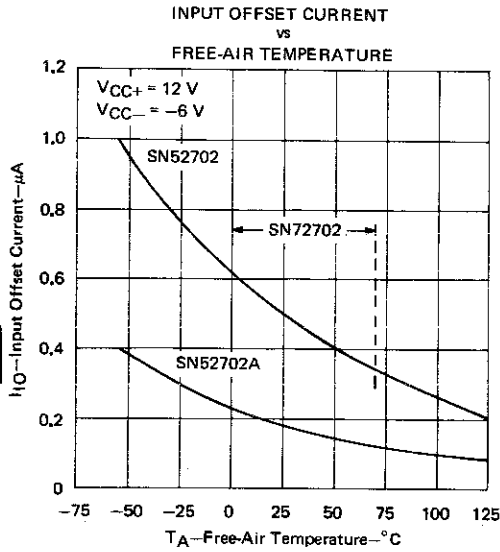

FIGURE 4

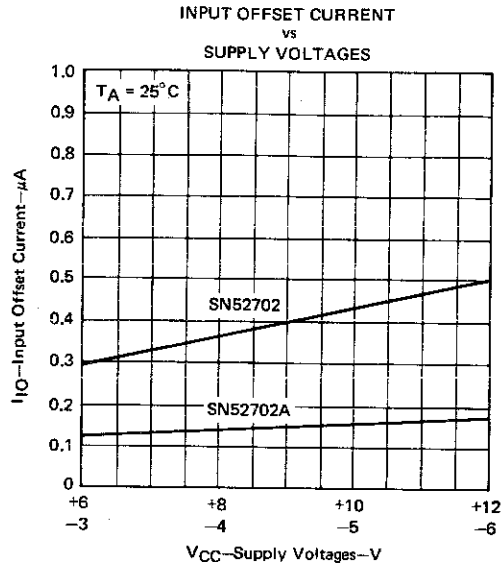

FIGURE 5

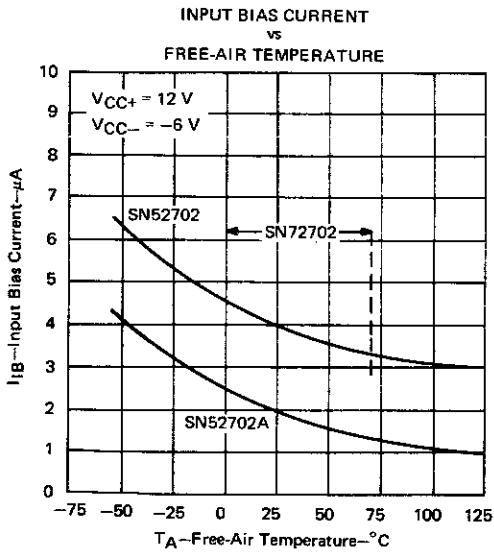

FIGURE 6

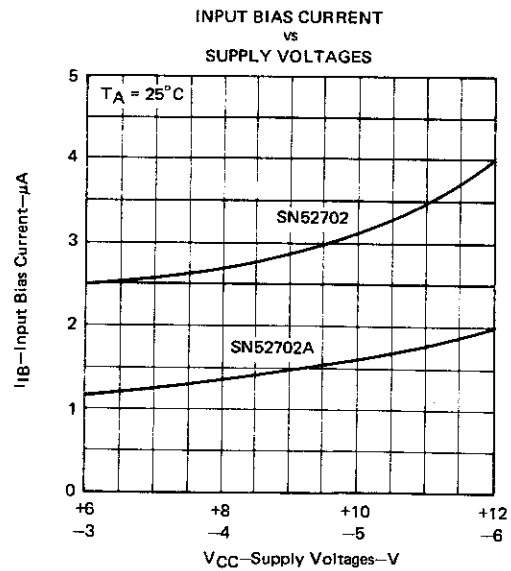
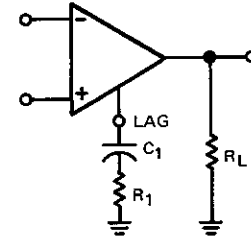
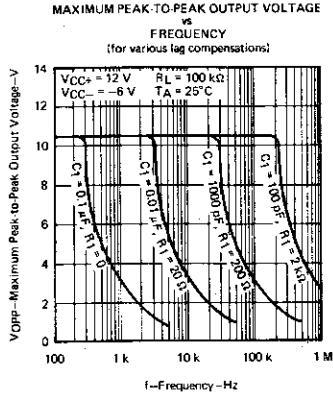

FIGURE 7

# CIRCUIT TYPES SN52702A, SN52702, SN72702 GENERAL-PURPOSE OPERATIONAL AMPLIFIERS

## TYPICAL CHARACTERISTICS



**LAG COMPENSATION CIRCUIT  
FOR FIGURES 8, 9, AND 10**

3

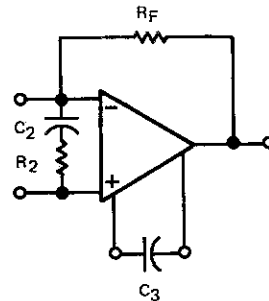
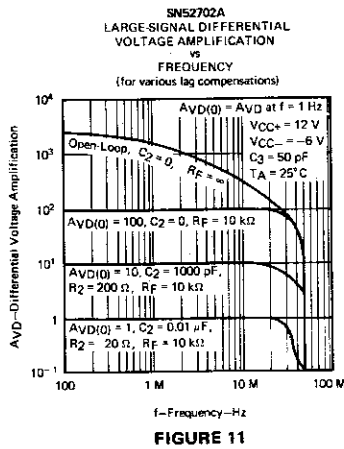
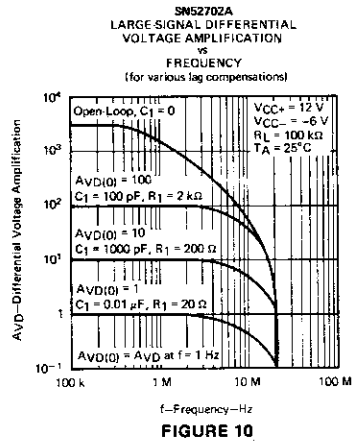
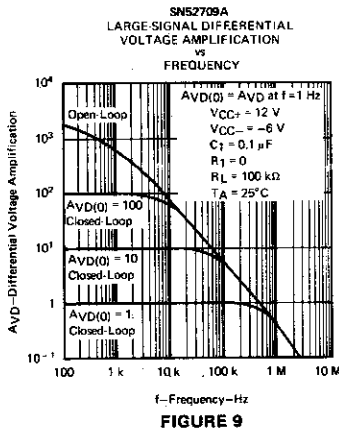

**LEAD-LAG COMPENSATION CIRCUIT  
FOR FIGURE 11**



# CIRCUIT TYPES SN52702A, SN52702, SN72702 GENERAL-PURPOSE OPERATIONAL AMPLIFIERS

## TYPICAL CHARACTERISTICS

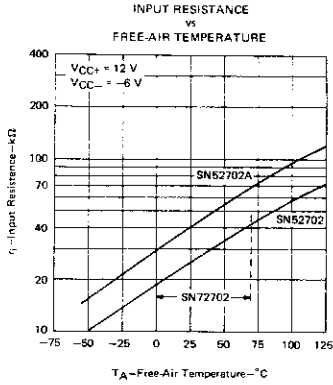

FIGURE 12

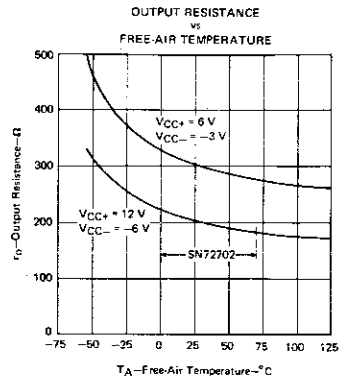

FIGURE 13

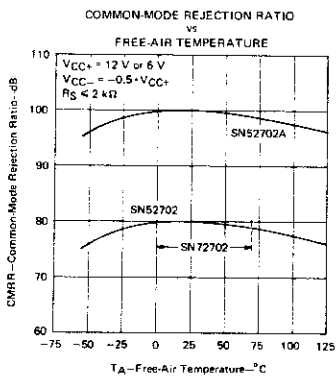

FIGURE 14

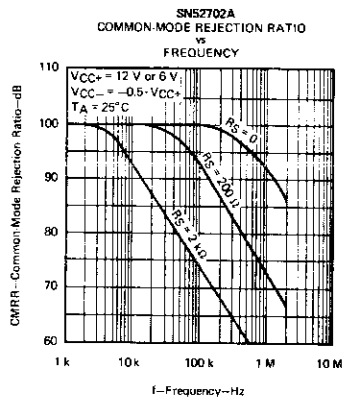

FIGURE 15

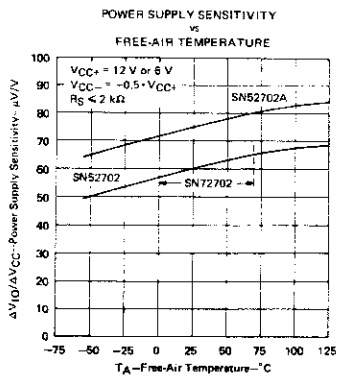

FIGURE 16

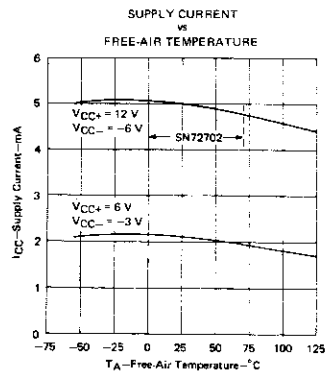

FIGURE 17

3