

**TYPES SN54181, SN54LS181, SN54S181,  
SN74181, SN74LS181, SN74S181**  
**ARITHMETIC LOGIC UNITS/FUNCTION GENERATORS**  
DECEMBER 1972 - REVISED DECEMBER 1983

- Full Look-Ahead for High-Speed Operations on Long Words
- Input Clamping Diodes Minimize Transmission-Line Effects
- Darlington Outputs Reduce Turn-Off Time
- Arithmetic Operating Modes:
  - Addition
  - Subtraction
  - Shift Operand A One Position
  - Magnitude Comparison
  - Plus Twelve Other Arithmetic Operations
- Logic Function Modes:
  - Exclusive-OR
  - Comparator
  - AND, NAND, OR, NOR
  - Plus Ten Other Logic Operations

SN54181, SN54LS181, SN54S181 ... J OR W PACKAGE  
SN74181 ... J OR N PACKAGE  
SN74LS181, SN74S181 ... DW, J OR N PACKAGE

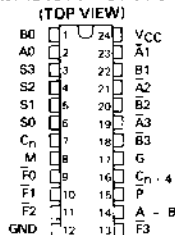

SN54LS181, SN54S181 ... FK PACKAGE  
SN74LS181, SN74S181 ... FN PACKAGE

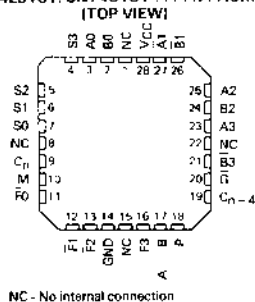

TYPICAL ADDITION TIMES

NUMBER OF BITS	ADDITION TIMES			PACKAGE COUNT		CARRY METHOD BETWEEN ALU's
	USING '181 AND '182	USING 'LS181 AND '182	USING 'S181 AND 'S182	ARITHMETIC/LOGIC UNITS	LOOK-AHEAD CARRY GENERATORS	
1 to 4	24 ns	24 ns	11 ns	1		NONE
5 to 8	36 ns	40 ns	18 ns	2		RIPPLE
9 to 16	36 ns	44 ns	19 ns	3 or 4	1	FULL LOOK-AHEAD
17 to 64	60 ns	68 ns	28 ns	5 to 16	2 to 5	FULL LOOK-AHEAD

**description**

The '181, 'LS181, and 'S181 are arithmetic logic units (ALU)/function generators that have a complexity of 75 equivalent gates on a monolithic chip. These circuits perform 16 binary arithmetic operations on two 4-bit words as shown in Tables 1 and 2. These operations are selected by the four function-select lines (S0, S1, S2, S3) and include addition, subtraction, decrement, and straight transfer. When performing arithmetic manipulations, the internal carries must be enabled by applying a low-level voltage to the mode control input (M). A full carry look-ahead scheme is made available in these devices for fast, simultaneous carry generation by means of two cascade-outputs (pins 15 and 17) for the four bits in the package. When used in conjunction with the SN54182, SN54S182, SN74182, or SN74S182, full carry look-ahead circuits, high-speed arithmetic operations can be performed. The typical addition times shown above illustrate the little additional time required for addition of longer words when full carry look-ahead is employed. The method of cascading '182 or 'S182 circuits with these ALU's to provide multi-level full carry look-ahead is illustrated under typical applications data for the '182 and 'S182.

If high speed is not of importance, a ripple-carry input (C<sub>n</sub>) and a ripple-carry output (C<sub>n+4</sub>) are available. However, the ripple-carry delay has also been minimized so that arithmetic manipulations for small word lengths can be performed without external circuitry.

**PRODUCTION DATA**

This document contains information current as of publication date. Products conform to specifications per the terms of Texas Instruments standard warranty. Production processing does not necessarily include testing of all parameters.



POST OFFICE BOX 225012 • DALLAS, TEXAS 75265

# TYPES SN54181, SN54LS181, SN54S181, SN74181, SN74LS181, SN74S181 ARITHMETIC LOGIC UNITS/FUNCTION GENERATORS

## description (continued)

The '181, 'LS181, and 'S181 will accommodate active-high or active-low data if the pin designations are interpreted as follows:

PIN NUMBER	2	1	23	22	21	20	19	18	9	10	11	13	7	16	15	17
Active-low data (Table 1)	$\bar{A}_0$	$\bar{B}_0$	$\bar{A}_1$	$\bar{B}_1$	$\bar{A}_2$	$\bar{B}_2$	$\bar{A}_3$	$\bar{B}_3$	$\bar{F}_0$	$\bar{F}_1$	$\bar{F}_2$	$\bar{F}_3$	$C_n$	$C_{n+4}$	$\bar{P}$	$\bar{G}$
Active-high data (Table 2)	$A_0$	$B_0$	$A_1$	$B_1$	$A_2$	$B_2$	$A_3$	$B_3$	$F_0$	$F_1$	$F_2$	$F_3$	$C_n$	$C_{n+4}$	$X$	$Y$

Subtraction is accomplished by 1's complement addition where the 1's complement of the subtrahend is generated internally. The resultant output is  $A-B-1$ , which requires an end-around or forced carry to provide  $A-B$ .

The '181, 'LS181, or 'S181 can also be utilized as a comparator. The  $A = B$  output is internally decoded from the function outputs ( $F_0, F_1, F_2, F_3$ ) so that when two words of equal magnitude are applied at the A and B inputs, it will assume a high level to indicate equality ( $A = B$ ). The ALU must be in the subtract mode with  $C_n = H$  when performing this comparison. The  $A = B$  output is open-collector so that it can be wire-AND connected to give a comparison for more than four bits. The carry output ( $C_{n+4}$ ) can also be used to supply relative magnitude information. Again, the ALU must be placed in the subtract mode by placing the function select inputs  $S_3, S_2, S_1, S_0$  at L, H, H, L, respectively.

INPUT $C_n$	OUTPUT $C_{n+4}$	ACTIVE-LOW DATA (FIGURE 1)	ACTIVE-HIGH DATA (FIGURE 2)
H	H	$A \geq B$	$A \leq B$
H	L	$A < B$	$A > B$
L	H	$A > B$	$A < B$
L	L	$A \leq B$	$A \geq B$

These circuits have been designed to not only incorporate all of the designer's requirements for arithmetic operations, but also to provide 16 possible functions of two Boolean variables without the use of external circuitry. These logic functions are selected by use of the four function-select inputs ( $S_0, S_1, S_2, S_3$ ) with the mode-control input (M) at a high level to disable the internal carry. The 16 logic functions are detailed in Tables 1 and 2 and include exclusive-OR, NAND, AND, NOR, and OR functions.

Series 54, 54LS, and 54S devices are characterized for operation over the full military temperature range of  $-55^\circ\text{C}$  to  $125^\circ\text{C}$ ; Series 74, 74LS, and 74S devices are characterized for operation from  $0^\circ\text{C}$  to  $70^\circ\text{C}$ .

## signal designations

The '181, 'LS181, and 'S181 together with the '182 and 'S182 can be used with the signal designations of either Figure 1 or Figure 2. The inversion indicators ( $\bar{\circ}$ ) and the bars over the terminal letter symbols (e.g.,  $\bar{C}$ ) each indicate that the associated input or output is active with respect to the selected function of the device when that input or output is low. That is, a low at  $\bar{C}$  means "do carry" while a high means "do not carry".

The logic functions and arithmetic operations obtained with signal designations of Figure 1 are given in Table 1; those obtained with signal designations of Figure 2 are given in Table 2.

TYPES SN54181, SN54LS181, SN54S181,  
SN74181, SN74LS181, SN74S181  
ARITHMETIC LOGIC UNITS/FUNCTION GENERATORS

signal designations (continued)

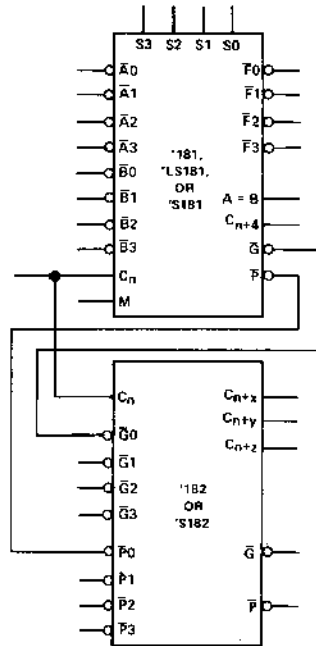

FIGURE 1

TABLE 1

SELECTION				ACTIVE-LOW DATA		
				M = H LOGIC FUNCTIONS	C <sub>n</sub> = L (no carry)	C <sub>n</sub> = H (with carry)
S3	S2	S1	S0			
L	L	L	L	$F = \bar{A}$	$F = A \text{ MINUS } 1$	$F = A$
L	L	L	H	$F = \overline{AB}$	$F = AB \text{ MINUS } 1$	$F = AB$
L	L	H	L	$F = \bar{A} + B$	$F = \overline{AB} \text{ MINUS } 1$	$F = \overline{AB}$
L	L	H	H	$F = 1$	$F = \text{MINUS } 1 \text{ (2's COMP)}$	$F = \text{ZERO}$
L	H	L	L	$F = \bar{A} + \bar{B}$	$F = A \text{ PLUS } (A + \bar{B})$	$F = A \text{ PLUS } (A + \bar{B}) \text{ PLUS } 1$
L	H	L	H	$F = \bar{B}$	$F = AB \text{ PLUS } (A + \bar{B})$	$F = AB \text{ PLUS } (A + \bar{B}) \text{ PLUS } 1$
L	H	H	L	$F = A \oplus \bar{B}$	$F = A \text{ MINUS } B \text{ MINUS } 1$	$F = A \text{ MINUS } B$
L	H	H	H	$F = A + \bar{B}$	$F = A + \bar{B}$	$F = (A + \bar{B}) \text{ PLUS } 1$
H	L	L	L	$F = \overline{AB}$	$F = A \text{ PLUS } (A + B)$	$F = A \text{ PLUS } (A + B) \text{ PLUS } 1$
H	L	L	H	$F = A \oplus B$	$F = A \text{ PLUS } B$	$F = A \text{ PLUS } B \text{ PLUS } 1$
H	L	H	L	$F = B$	$F = \overline{AB} \text{ PLUS } (A + B)$	$F = \overline{AB} \text{ PLUS } (A + B) \text{ PLUS } 1$
H	L	H	H	$F = A + B$	$F = (A + B)$	$F = (A + B) \text{ PLUS } 1$
H	H	L	L	$F = 0$	$F = A$	$F = A \text{ PLUS } A \text{ PLUS } 1$
H	H	L	H	$F = \overline{AB}$	$F = AB \text{ PLUS } A$	$F = AB \text{ PLUS } A \text{ PLUS } 1$
H	H	H	L	$F = AB$	$F = \overline{AB} \text{ PLUS } A$	$F = \overline{AB} \text{ PLUS } A \text{ PLUS } 1$
H	H	H	H	$F = A$	$F = A$	$F = A \text{ PLUS } 1$

**TYPES SN54181, SN54LS181, SN54S181,  
SN74181, SN74LS181, SN74S181  
ARITHMETIC LOGIC UNITS/FUNCTION GENERATORS**

signal designations (continued)

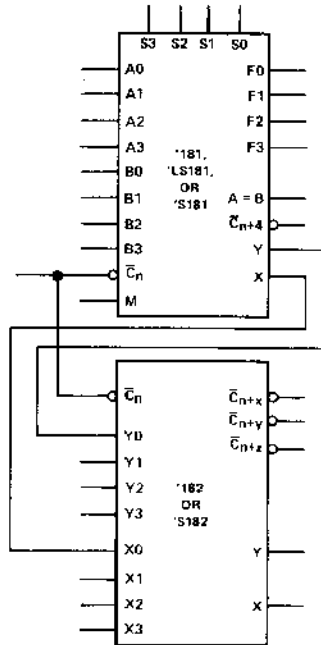

FIGURE 2

TABLE 2

SELECTION				ACTIVE-HIGH DATA		
				M = H LOGIC FUNCTIONS	M = L: ARITHMETIC OPERATIONS	
S3	S2	S1	S0		C <sub>n</sub> = H (no carry)	C <sub>n</sub> = L (with carry)
L	L	L	L	$F = \overline{A}$	$F = A$	$F = A \text{ PLUS } 1$
L	L	L	H	$F = \overline{A + B}$	$F = A + B$	$F = (A \cdot B) \text{ PLUS } 1$
L	L	H	L	$F = \overline{AB}$	$F = A + \overline{B}$	$F = (A + \overline{B}) \text{ PLUS } 1$
L	L	H	H	$F = 0$	$F = \text{MINUS } 1 \text{ (2's COMPL)}$	$F = \text{ZERO}$
L	H	L	L	$F = \overline{AB}$	$F = A \text{ PLUS } \overline{AB}$	$F = A \text{ PLUS } \overline{AB} \text{ PLUS } 1$
L	H	L	H	$F = \overline{B}$	$F = (A + B) \text{ PLUS } \overline{AB}$	$F = (A + B) \text{ PLUS } \overline{AB} \text{ PLUS } 1$
L	H	H	L	$F = A \oplus B$	$F = A \text{ MINUS } B \text{ MINUS } 1$	$F = A \text{ MINUS } B$
L	H	H	H	$F = \overline{AB}$	$F = \overline{AB} \text{ MINUS } 1$	$F = \overline{AB}$
H	L	L	L	$F = \overline{A + B}$	$F = A \text{ PLUS } \overline{AB}$	$F = A \text{ PLUS } \overline{AB} \text{ PLUS } 1$
H	L	L	H	$F = A \oplus B$	$F = A \text{ PLUS } B$	$F = A \text{ PLUS } B \text{ PLUS } 1$
H	L	H	L	$F = B$	$F = (A + \overline{B}) \text{ PLUS } \overline{AB}$	$F = (A + \overline{B}) \text{ PLUS } \overline{AB} \text{ PLUS } 1$
H	L	H	H	$F = \overline{AB}$	$F = \overline{AB} \text{ MINUS } 1$	$F = \overline{AB}$
H	H	L	L	$F = 1$	$F = A$	$F = A \text{ PLUS } A \text{ PLUS } 1$
H	H	L	H	$F = A + \overline{B}$	$F = (A + B) \text{ PLUS } A$	$F = (A + B) \text{ PLUS } A \text{ PLUS } 1$
H	H	H	L	$F = A + B$	$F = (A + \overline{B}) \text{ PLUS } A$	$F = (A + \overline{B}) \text{ PLUS } A \text{ PLUS } 1$
H	H	H	H	$F = A$	$F = A \text{ MINUS } 1$	$F = A$

3

TTL DEVICES

TYPES SN54181, SN54LS181, SN54S181, SN74181, SN74LS181, SN74S181  
 ARITHMETIC LOGIC UNITS/FUNCTION GENERATORS

logic diagram

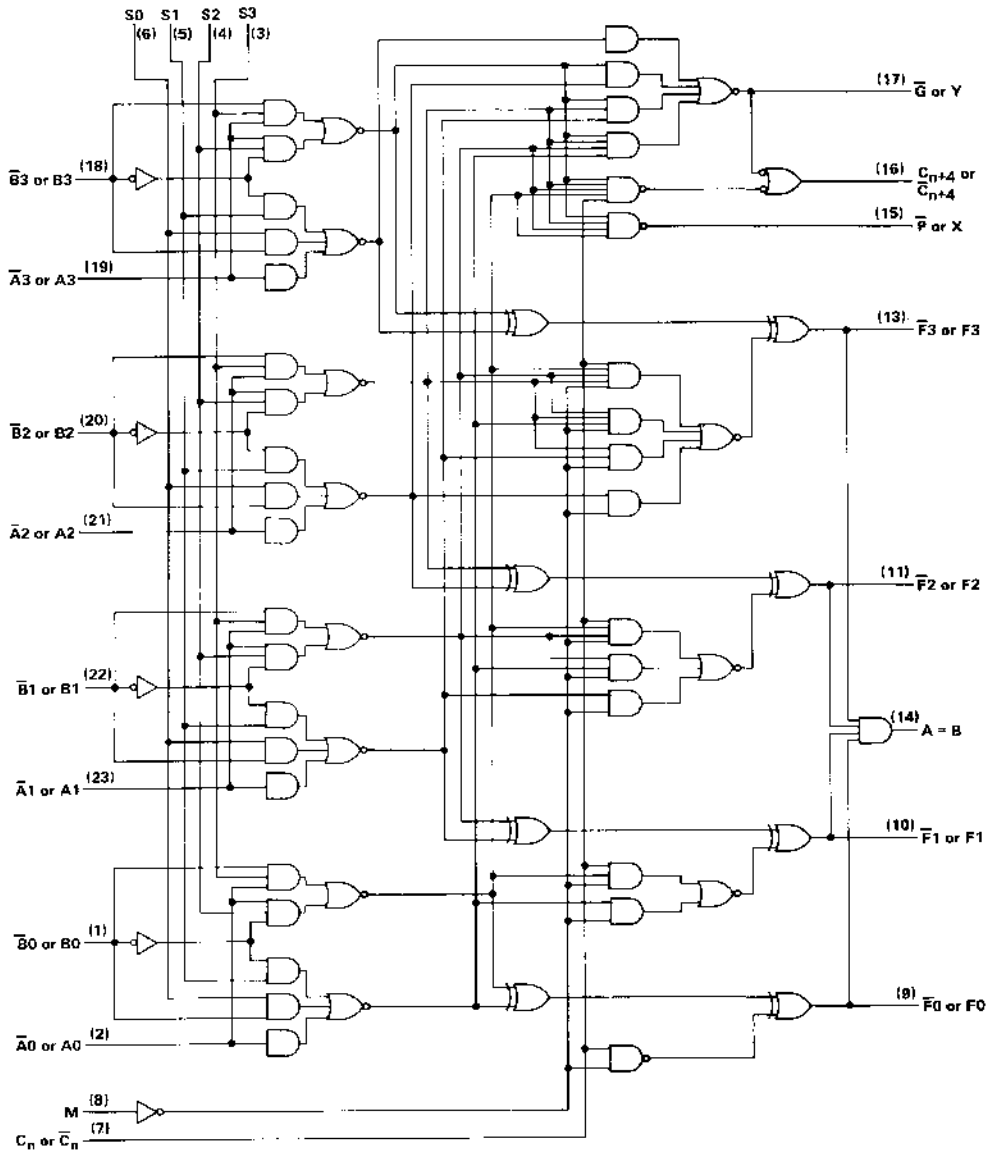

Pin numbers shown on logic notation are for DW, J or N packages.

**3**  
 TTL DEVICES

# TYPES SN54181, SN74181 ARITHMETIC LOGIC UNITS/FUNCTION GENERATORS

## absolute maximum ratings over operating free-air temperature range (unless otherwise noted)

Supply voltage, $V_{CC}$ (see Note 1)	7 V
Input voltage	5.5 V
Interemitter voltage (see Note 2)	5.5 V
Operating free-air temperature range: SN54181	-55°C to 125°C
SN74181	0°C to 70°C
Storage temperature range	-65°C to 150°C

- NOTES: 1. Voltage values, except interemitter voltage, are with respect to network ground terminal.  
2. This is the voltage between two emitters of a multiple-emitter transistor. For this circuit, this rating applies to each  $\bar{A}$  input in conjunction with inputs S2 or S3, and to each  $\bar{B}$  input in conjunction with inputs S0 or S3.

## recommended operating conditions

	SN54181			SN74181			UNIT
	MIN	NOM	MAX	MIN	NOM	MAX	
Supply voltage, $V_{CC}$	4.5	5	5.5	4.75	5	5.25	V
High-level output current, $I_{OH}$ (All outputs except A = B)			-800			-800	$\mu$ A
Low-level output current, $I_{OL}$			16			16	mA
Operating free-air temperature, $T_A$	-55		125	0		70	°C

## electrical characteristics over recommended operating free-air temperature range (unless otherwise noted)

PARAMETER		TEST CONDITIONS†	SN54181			SN74181			UNIT
			MIN	TYP‡	MAX	MIN	TYP‡	MAX	
$V_{IH}$	High-level input voltage		2			2			V
$V_{IL}$	Low-level input voltage					0.8			V
$V_{IK}$	Input clamp voltage	$V_{CC} = \text{MIN}, I_I = -12 \text{ mA}$	-1.5			-1.5			V
$V_{OH}$	High-level output voltage, any output except A = B	$V_{CC} = \text{MIN}, V_{IH} = 2 \text{ V}, V_{IL} = 0.8 \text{ V}, I_{OH} = -800 \mu\text{A}$	2.4	3.4		2.4	3.4		V
$I_{OH}$	High-level output current, A = B output only	$V_{CC} = \text{MIN}, V_{IH} = 2 \text{ V}, V_{IL} = 0.8 \text{ V}, V_{OH} = 5.5 \text{ V}$	250			250			$\mu$ A
$V_{OL}$	Low-level output voltage	$V_{CC} = \text{MIN}, V_{IH} = 2 \text{ V}, V_{IL} = 0.8 \text{ V}, I_{OL} = 16 \text{ mA}$	0.2 0.4			0.2 0.4			V
$I_I$	Input current at maximum input voltage	$V_{CC} = \text{MAX}, V_I = 5.5 \text{ V}$	1			1			mA
$I_{IH}$	High-level input current	Mode input	40			40			$\mu$ A
		Any $\bar{A}$ or $\bar{B}$ input	120			120			
		Any S input	160			160			
		Carry input	200			200			
$I_{IL}$	Low-level input current	Mode input	-1.6			-1.6			mA
		Any $\bar{A}$ or $\bar{B}$ input	-4.8			-4.8			
		Any S input	-6.4			-6.4			
		Carry input	-8			-8			
$I_{OS}$	Short-circuit output current, any output except A = B§	$V_{CC} = \text{MAX}$	-20	55	-18	57	mA		
$I_{CC}$	Supply current	$V_{CC} = \text{MAX}$ , Condition A	88	127	88	140	mA		
		See Note 3, Condition B	94	135	94	150	mA		

† For conditions shown as MIN or MAX, use the appropriate value specified under recommended operating conditions.

‡ All typical values are at  $V_{CC} = 5 \text{ V}, T_A = 25^\circ \text{C}$ .

§ Not more than one output should be shorted at a time.

NOTE 3: With outputs open,  $I_{CC}$  is measured for the following conditions:

A. S0 through S3, M, and  $\bar{A}$  inputs are at 4.5 V, all other inputs are grounded.

B. S0 through S3 and M are at 4.5 V, all other inputs are grounded.

3 TTL DEVICES

# TYPES SN54181, SN74181 ARITHMETIC LOGIC UNITS/FUNCTION GENERATORS

switching characteristics,  $V_{CC} = 5\text{ V}$ ,  $T_A = 25^\circ\text{C}$  ( $C_L = 15\text{ pF}$ ,  $R_L = 400\ \Omega$ , see note 4)

PARAMETER <sup>1</sup>	FROM (INPUT)	TO (OUTPUT)	TEST CONDITIONS	MIN	TYP	MAX	UNIT
$t_{PLH}$	$C_n$	$C_{n+4}$			12	18	ns
$t_{PHL}$					13	19	
$t_{PLH}$	Any $\bar{A}$ or $\bar{B}$	$C_{n+4}$	$M = 0\text{ V}$ , $S_0 = S_3 = 4.5\text{ V}$ , $S_1 = S_2 = 0\text{ V}$ (SUM mode)		28	43	ns
$t_{PHL}$					27	41	
$t_{PLH}$	Any $\bar{A}$ or $\bar{B}$	$C_{n+4}$	$M = 0\text{ V}$ , $S_0 = S_3 = 0\text{ V}$ , $S_1 = S_2 = 4.5\text{ V}$ (DIFF mode)		35	50	ns
$t_{PHL}$					33	50	
$t_{PLH}$	$C_n$	Any $\bar{F}$	$M = 0\text{ V}$ (SUM or DIFF mode)		13	19	ns
$t_{PHL}$					12	18	
$t_{PLH}$	Any $\bar{A}$ or $\bar{B}$	$\bar{G}$	$M = 0\text{ V}$ , $S_0 = S_3 = 4.5\text{ V}$ , $S_1 = S_2 = 0\text{ V}$ (SUM mode)		13	19	ns
$t_{PHL}$					13	19	
$t_{PLH}$	Any $\bar{A}$ or $\bar{B}$	$\bar{G}$	$M = 0\text{ V}$ , $S_0 = S_3 = 0\text{ V}$ , $S_1 = S_2 = 4.5\text{ V}$ (DIFF mode)		17	25	ns
$t_{PHL}$					17	25	
$t_{PLH}$	Any $\bar{A}$ or $\bar{B}$	$\bar{P}$	$M = 0\text{ V}$ , $S_0 = S_3 = 4.5\text{ V}$ , $S_1 = S_2 = 0\text{ V}$ (SUM mode)		13	19	ns
$t_{PHL}$					17	25	
$t_{PLH}$	Any $\bar{A}$ or $\bar{B}$	$\bar{P}$	$M = 0\text{ V}$ , $S_0 = S_3 = 0\text{ V}$ , $S_1 = S_2 = 4.5\text{ V}$ (DIFF mode)		17	25	ns
$t_{PHL}$					17	25	
$t_{PLH}$	$\bar{A}_i$ or $\bar{B}_i$	$\bar{F}_i$	$M = 0\text{ V}$ , $S_0 = S_3 = 4.5\text{ V}$ , $S_1 = S_2 = 0\text{ V}$ (SUM mode)		28	42	ns
$t_{PHL}$					21	32	
$t_{PLH}$	$\bar{A}_i$ or $\bar{B}_i$	$\bar{F}_i$	$M = 0\text{ V}$ , $S_0 = S_3 = 0\text{ V}$ , $S_1 = S_2 = 4.5\text{ V}$ (DIFF mode)		32	48	ns
$t_{PHL}$					23	34	
$t_{PLH}$	$\bar{A}_i$ or $\bar{B}_i$	$\bar{F}_i$	$M = 4.5\text{ V}$ (logic mode)		32	48	ns
$t_{PHL}$					23	34	
$t_{PLH}$	Any $\bar{A}$ or $\bar{B}$	$A = B$	$M = 0\text{ V}$ , $S_0 = S_3 = 0\text{ V}$ , $S_1 = S_2 = 4.5\text{ V}$ (DIFF mode)		35	50	ns
$t_{PHL}$					32	48	

<sup>1</sup>  $t_{PLH}$  = propagation delay time, low-to-high-level output

$t_{PHL}$  = propagation delay time, high-to-low-level output

NOTE 4: See General Information Section for load circuits and voltage waveforms.

### schematics of inputs and outputs

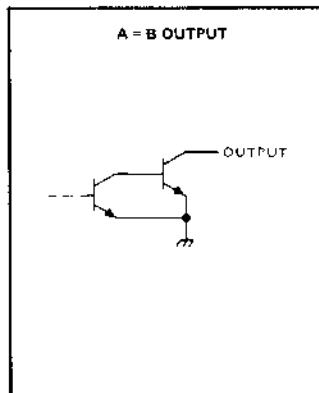
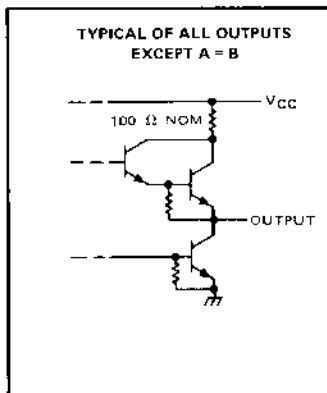
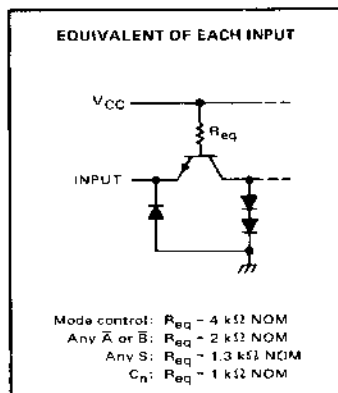

3

TTL DEVICES

# TYPES SN54LS181, SN74LS181 ARITHMETIC LOGIC UNITS/FUNCTION GENERATORS

absolute maximum ratings over recommended operating free-air temperature range (unless otherwise noted)

Supply voltage, $V_{CC}$ (see Note 1)	7 V
Input voltage	5.5 V
Interemitter voltage (see Note 2)	5.5 V
Operating free-air temperature range: SN54LS181	-55°C to 125°C
SN74LS181	0°C to 70°C
Storage temperature range	-65°C to 150°C

NOTES: 1. Voltage values, except interemitter voltage, are with respect to network ground terminal.  
2. This is the voltage between two emitters of a multiple-emitter transistor. For this circuit, this rating applies to each  $\bar{A}$  input in conjunction with inputs S2 or S3, and to each  $\bar{B}$  input in conjunction with inputs S0 or S3.

## recommended operating conditions

	SN54LS181			SN74LS181			UNIT
	MIN	NOM	MAX	MIN	NOM	MAX	
Supply voltage, $V_{CC}$	4.5	5	5.5	4.75	5	5.25	V
High-level output current, $I_{OH}$ (All outputs except A = B)			-400			-400	$\mu$ A
Low-level output current, $I_{OL}$			4			8	mA
Operating free-air temperature, $T_A$	-55		125	0		70	°C

electrical characteristics over recommended operating free-air temperature range (unless otherwise noted)

PARAMETER		TEST CONDITIONS†	SN54LS181		SN74LS181		UNIT	
			MIN	TYP‡	MAX	MIN		TYP‡
$V_{IH}$	High-level input voltage		2		2		V	
$V_{IL}$	Low-level input voltage			0.7		0.8	V	
$V_{IK}$	Input clamp voltage	$V_{CC} = \text{MIN}$ , $I_I = -18 \text{ mA}$		-1.5		-1.5	V	
$V_{OH}$	High-level output voltage, any output except A = B	$V_{CC} = \text{MIN}$ , $V_{IH} = 2 \text{ V}$ , $V_{IL} = V_{IL \text{ max}}$ , $I_{OH} = -400 \mu\text{A}$	2.5	3.4	2.7	3.4	V	
$I_{OH}$	High-level output current, A = B output only	$V_{CC} = \text{MIN}$ , $V_{IH} = 2 \text{ V}$ , $V_{IL} = V_{IL \text{ max}}$ , $V_{OH} = 5.5 \text{ V}$		100		100	$\mu$ A	
$V_{OL}$	Low-level output voltage	All outputs	$V_{CC} = \text{MIN}$ , $V_{IH} = 2 \text{ V}$ , $V_{IL} = V_{IL \text{ max}}$	$I_{OL} = 4 \text{ mA}$	0.25	0.4	0.25	0.4
		Output $\bar{G}$		$I_{OL} = 8 \text{ mA}$			0.35	0.5
		Output P		$I_{OL} = 16 \text{ mA}$	0.47	0.7	0.47	0.7
				$I_{OL} = 8 \text{ mA}$	0.35	0.6	0.35	0.5
$I_I$	Input current at max. input voltage	Mode input	$V_{CC} = \text{MAX}$ , $V_I = 5.5 \text{ V}$		0.1		0.1	
		Any $\bar{A}$ or $\bar{B}$ input			0.3		0.3	
		Any S input			0.4		0.4	
		Carry input			0.5		0.5	
$I_{IH}$	High-level input current	Mode input	$V_{CC} = \text{MAX}$ , $V_I = 2.7 \text{ V}$		20		20	
		Any $\bar{A}$ or $\bar{B}$ input			60		60	
		Any S input			80		80	
		Carry input			100		100	
$I_{IL}$	Low-level input current	Mode input	$V_{CC} = \text{MAX}$ , $V_I = 0.4 \text{ V}$		-0.4		-0.4	
		Any $\bar{A}$ or $\bar{B}$ input			-1.2		-1.2	
		Any S input			-1.6		-1.6	
		Carry input			-2		-2	
$I_{OS}$	Short-circuit output current, any output except A = B §	$V_{CC} = \text{MAX}$	-6	-40	-5	-42	mA	
$I_{CC}$	Supply current	$V_{CC} = \text{MAX}$ , See Note 3	Condition A	20	32	20	34	
			Condition B	21	35	21	37	

†For conditions shown as MIN or MAX, use the appropriate value specified under recommended operating conditions.

‡All typical values are at  $V_{CC} = 5 \text{ V}$ ,  $T_A = 25^\circ \text{C}$ .

§Not more than one output should be shorted at a time.

NOTE 3: With outputs open,  $I_{CC}$  is measured for the following conditions:

- A. S0 through S3, M, and  $\bar{A}$  inputs are at 4.5 V, all other inputs are grounded.
- B. S0 through S3 and M are at 4.5 V, all other inputs are grounded.

3

TTL DEVICES



# TYPES SN54LS181, SN74LS181 ARITHMETIC LOGIC UNITS/FUNCTION GENERATORS

switching characteristics,  $V_{CC} = 5\text{ V}$ ,  $T_A = 25^\circ\text{ C}$ , ( $C_L = 15\text{ pF}$ ,  $R_L = 2\text{ k}\Omega$ , see note 4)

PARAMETER <sup>1</sup>	FROM (INPUT)	TO (OUTPUT)	TEST CONDITIONS	MIN	TYP	MAX	UNIT
$t_{PLH}$	$C_n$	$C_{n+4}$		18	27		ns
$t_{PHL}$				13	20		ns
$t_{PLH}$	Any $\bar{A}$ or $\bar{B}$	$C_{n+4}$	$M = 0\text{ V}$ , $S_0 = S_3 = 4.5\text{ V}$ , $S_1 = S_2 = 0\text{ V}$ (SUM mode)	25	38		ns
$t_{PHL}$				25	38		ns
$t_{PLH}$	Any $\bar{A}$ or $\bar{B}$	$C_{n+4}$	$M = 0\text{ V}$ , $S_0 = S_3 = 0\text{ V}$ $S_1 = S_2 = 4.5\text{ V}$ (DIFF mode)	27	41		ns
$t_{PHL}$				27	41		ns
$t_{PLH}$	$C_n$	Any F	$M = 0\text{ V}$ (SUM or DIFF mode)	17	26		ns
$t_{PHL}$				13	20		ns
$t_{PLH}$	Any $\bar{A}$ or $\bar{B}$	$\bar{C}$	$M = 0\text{ V}$ , $S_0 = S_3 = 4.5\text{ V}$ , $S_1 = S_2 = 0\text{ V}$ (SUM mode)	19	29		ns
$t_{PHL}$				15	23		ns
$t_{PLH}$	Any $\bar{A}$ or $\bar{B}$	$\bar{C}$	$M = 0\text{ V}$ , $S_0 = S_3 = 0\text{ V}$ , $S_1 = S_2 = 4.5\text{ V}$ (DIFF mode)	21	32		ns
$t_{PHL}$				21	32		ns
$t_{PLH}$	Any $\bar{A}$ or $\bar{B}$	F	$M = 0\text{ V}$ , $S_0 = S_3 = 4.5\text{ V}$ , $S_1 = S_2 = 0\text{ V}$ , (SUM mode)	20	30		ns
$t_{PHL}$				20	30		ns
$t_{PLH}$	Any $\bar{A}$ or $\bar{B}$	F	$M = 0\text{ V}$ , $S_0 = S_3 = 0\text{ V}$ , $S_1 = S_2 = 4.5\text{ V}$ (DIFF mode)	22	33		ns
$t_{PHL}$				22	33		ns
$t_{PLH}$	$\bar{A}_i$ or $\bar{B}_i$	$F_i$	$M = 0\text{ V}$ , $S_0 = S_3 = 4.5\text{ V}$ , $S_1 = S_2 = 0\text{ V}$ (SUM mode)	21	32		ns
$t_{PHL}$				13	20		ns
$t_{PLH}$	$\bar{A}_i$ or $\bar{B}_i$	$F_i$	$M = 0\text{ V}$ , $S_0 = S_3 = 0\text{ V}$ , $S_1 = S_2 = 4.5\text{ V}$ (DIFF mode)	21	32		ns
$t_{PHL}$				21	32		ns
$t_{PLH}$	$\bar{A}_i$ or $\bar{B}_i$	$F_i$	$M = 4.5\text{ V}$ (logic mode)	22	33		ns
$t_{PHL}$				26	38		ns
$t_{PLH}$	Any $\bar{A}$ or $\bar{B}$	A = B	$M = 0\text{ V}$ , $S_0 = S_3 = 0\text{ V}$ , $S_1 = S_2 = 4.5\text{ V}$ (DIFF mode)	33	50		ns
$t_{PHL}$				41	62		ns

<sup>1</sup>  $t_{PLH}$   $\equiv$  propagation delay time, low-to-high-level output

$t_{PHL}$   $\equiv$  propagation delay time, high-to-low-level output

NOTE 4: See General Information Section for load circuits and voltage waveforms.

### schematics of inputs and outputs

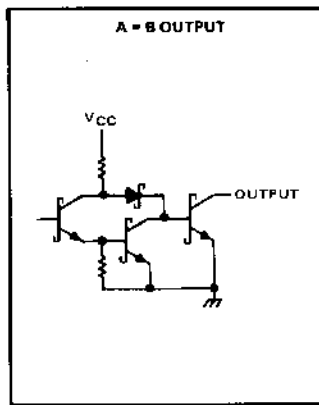
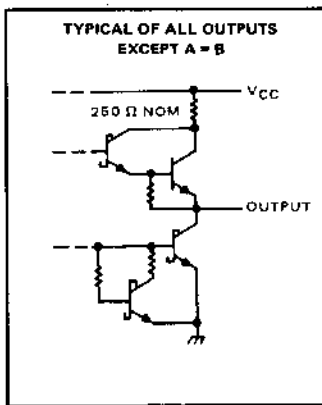
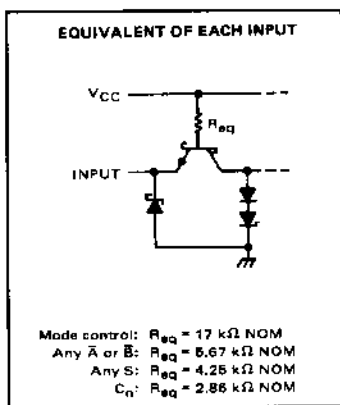

3

TTL DEVICES

# TYPES SN54S181, SN74S181 ARITHMETIC LOGIC UNITS/FUNCTION GENERATORS

absolute maximum ratings over operating free-air temperature range (unless otherwise noted)

Supply voltage, $V_{CC}$ (see Note 1)	7 V
Input voltage	5.5 V
Interemitter voltage (see Note 2)	5.5 V
Operating free-air temperature: SN54S181	-55°C to 125°C
SN74S181	0°C to 70°C
Storage temperature range	-65°C to 150°C

NOTES: 1. Voltage values, except interemitter voltage, are with respect to network ground terminal.  
2. This is the voltage between two emitters of a multiple-emitter transistor. For this circuit, this rating applies to each  $\bar{A}$  input in conjunction with inputs S2 or S3, and to each  $\bar{B}$  input in conjunction with inputs S0 or S3.

recommended operating conditions

	SN54S181			SN74S181			UNIT
	MIN	NOM	MAX	MIN	NOM	MAX	
Supply voltage, $V_{CC}$	4.5	5	5.5	4.75	5	5.25	V
High-level output current, $I_{OH}$ (All outputs except A = B)			-1			-1	mA
Low-level output current, $I_{OL}$			20			20	mA
Operating free-air temperature, $T_A$	-55		125	0		70	°C

electrical characteristics over recommended operating free-air temperature range (unless otherwise noted)

PARAMETER	TEST CONDITIONS <sup>†</sup>	SN54S181			SN74S181			UNIT
		MIN	TYP <sup>‡</sup>	MAX	MIN	TYP <sup>‡</sup>	MAX	
$V_{IH}$ High-level input voltage		2			2			V
$V_{IL}$ Low-level input voltage				0.8			0.8	V
$V_{IK}$ Input clamp voltage	$V_{CC} = \text{MIN.}$ , $I_I = -18 \text{ mA}$			-1.2			-1.2	V
$V_{OH}$ High-level output voltage, any output except A = B	$V_{CC} = \text{MIN.}$ , $V_{IH} = 2 \text{ V}$ , $V_{IL} = 0.8 \text{ V}$ , $I_{OH} = -1 \text{ mA}$	2.5	3.4		2.7	3.4		V
$I_{OH}$ High-level output current, A = B output only	$V_{CC} = \text{MIN.}$ , $V_{IH} = 2 \text{ V}$ , $V_{IL} = 0.8 \text{ V}$ , $V_{OH} = 5.5 \text{ V}$			250			250	$\mu\text{A}$
$V_{OL}$ Low-level output voltage	$V_{CC} = \text{MIN.}$ , $V_{IH} = 2 \text{ V}$ , $V_{IL} = 0.8 \text{ V}$ , $I_{OL} = 20 \text{ mA}$			0.5			0.5	V
$I_I$ Input current at maximum input voltage	$V_{CC} = \text{MAX.}$ , $V_I = 5.5 \text{ V}$			1			1	mA
$I_{IH}$ High-level input current	Mode input			50			50	$\mu\text{A}$
	Any $\bar{A}$ or $\bar{B}$ input	$V_{CC} = \text{MAX.}$ , $V_I = 2.5 \text{ V}$		150			150	
	Any S input			200			200	
	Carry input			250			250	
$I_{IL}$ Low-level input current	Mode input		$V_{CC} = \text{MAX.}$ , $V_I = 0.5 \text{ V}$		-2			2
	Any $\bar{A}$ or $\bar{B}$ input			-6			-6	
	Any S input			-8			-8	
	Carry input			-10			-10	
$I_{OS}$ Short-circuit output current, any output except A = B <sup>§</sup>	$V_{CC} = \text{MAX.}$	40		-100	40		-100	mA
$I_{CC}$ Supply current	$V_{CC} = \text{MAX.}$ , $T_A = 125^\circ\text{C}$ , W package only See Note 3			195				mA
	$V_{CC} = \text{MAX.}$ , See Note 3			120	220		120	

<sup>†</sup> For conditions shown as MIN or MAX, use the appropriate value specified under recommended operating conditions.

<sup>‡</sup> All typical values are at  $V_{CC} = 5 \text{ V}$ ,  $T_A = 25^\circ\text{C}$ .

<sup>§</sup> Not more than one output should be shorted at a time.

NOTE 3:  $I_{CC}$  is measured for the following conditions (the typical and maximum values apply to both):

- A. S0 through S3, M, and  $\bar{A}$  inputs are at 4.5 V, all other inputs are grounded, and all outputs are open.
- B. S0 through S3 and M are at 4.5 V, all other inputs grounded, and all outputs are open.

3 TTL DEVICES

# TYPES SN54S181, SN74S181 ARITHMETIC LOGIC UNITS/FUNCTION GENERATORS

switching characteristics,  $V_{CC} = 5\text{ V}$ ,  $T_A = 25^\circ\text{C}$  ( $C_L = 15\text{ pF}$ ,  $R_L = 280\ \Omega$ , see note 4)

PARAMETER <sup>1</sup>	FROM (INPUT)	TO (OUTPUT)	TEST CONDITIONS	MIN	TYP	MAX	UNIT
$t_{PLH}$	$C_n$	$C_{n+4}$			7	10.5	ns
$t_{PHL}$					7	10.5	
$t_{PLH}$	Any $\bar{A}$ or $\bar{B}$	$C_{n+4}$	$M = 0\text{ V}, S_0 = S_3 = 4.5\text{ V},$ $S_1 = S_2 = 0\text{ V}$ (SUM mode)		12.5	18.5	ns
$t_{PHL}$					12.5	18.5	
$t_{PLH}$	Any $\bar{A}$ or $\bar{B}$	$C_{n+4}$	$M = 0\text{ V}, S_0 = S_3 = 0\text{ V},$ $S_1 = S_2 = 4.5\text{ V}$ (DIFF mode)		15.5	23	ns
$t_{PHL}$					15.5	23	
$t_{PLH}$	$C_n$	Any $\bar{F}$	$M = 0\text{ V}$ (SUM or DIFF mode)		7	12	ns
$t_{PHL}$					7	12	
$t_{PLH}$	Any $\bar{A}$ or $\bar{B}$	$\bar{G}$	$M = 0\text{ V}, S_0 = S_3 = 4.5\text{ V},$ $S_1 = S_2 = 0\text{ V}$ (SUM mode)		8	12	ns
$t_{PHL}$					7.5	12	
$t_{PLH}$	Any $\bar{A}$ or $\bar{B}$	$\bar{G}$	$M = 0\text{ V}, S_0 = S_3 = 0\text{ V},$ $S_1 = S_2 = 4.5\text{ V}$ (DIFF mode)		10.5	15	ns
$t_{PHL}$					10.5	15	
$t_{PLH}$	Any $\bar{A}$ or $\bar{B}$	$\bar{P}$	$M = 0\text{ V}, S_0 = S_3 = 4.5\text{ V},$ $S_1 = S_2 = 0\text{ V}$ (SUM mode)		7.5	12	ns
$t_{PHL}$					7.5	12	
$t_{PLH}$	Any $\bar{A}$ or $\bar{B}$	$\bar{P}$	$M = 0\text{ V}, S_0 = S_3 = 0\text{ V},$ $S_1 = S_2 = 4.5\text{ V}$ (DIFF mode)		10.5	15	ns
$t_{PHL}$					10.5	15	
$t_{PLH}$	$\bar{A}_i$ or $\bar{B}_i$	$\bar{F}_i$	$M = 0\text{ V}, S_0 = S_3 = 4.5\text{ V},$ $S_1 = S_2 = 0\text{ V}$ (SUM mode)		11	16.5	ns
$t_{PHL}$					11	16.5	
$t_{PLH}$	$\bar{A}_i$ or $\bar{B}_i$	$F_i$	$M = 0\text{ V}, S_0 = S_3 = 0\text{ V},$ $S_1 = S_2 = 4.5\text{ V}$ (DIFF mode)		14	20	ns
$t_{PHL}$					14	22	
$t_{PLH}$	$\bar{A}_i$ or $\bar{B}_i$	$F_i$	$M = 4.5\text{ V}$ (logic mode)		14	20	ns
$t_{PHL}$					14	22	
$t_{PLH}$	Any $\bar{A}$ or $\bar{B}$	A B	$M = 0\text{ V}, S_0 = S_3 = 0\text{ V},$ $S_1 = S_2 = 4.5\text{ V}$ (DIFF mode)		15	23	ns
$t_{PHL}$					20	30	

<sup>1</sup> $t_{PLH}$  propagation delay time, low to high-level output

$t_{PHL}$  propagation delay time, high to low-level output

NOTE 4: See General Information Section for load circuits and voltage waveforms.

### schematics of inputs and outputs

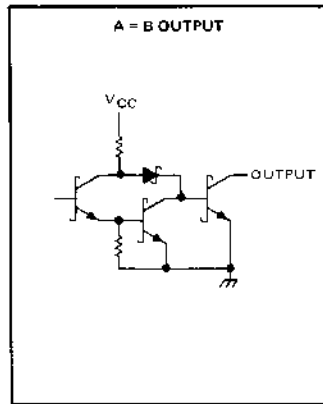
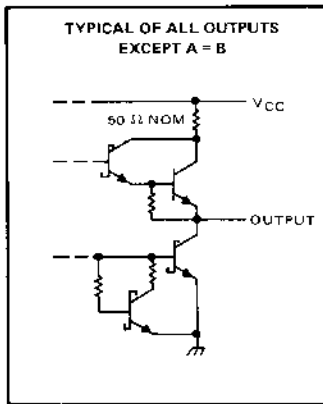
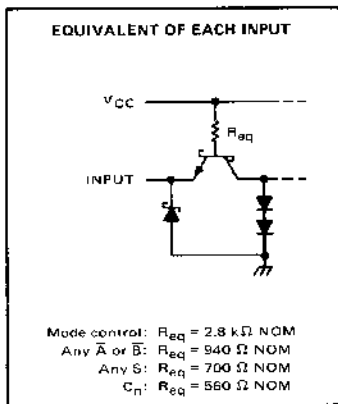

TTL DEVICES

TYPES SN54181, SN54LS181, SN54S181, SN74181, SN74LS181, SN74S181  
ARITHMETIC LOGIC UNITS/FUNCTION GENERATORS

PARAMETER MEASUREMENT INFORMATION

SUM MODE TEST TABLE

FUNCTION INPUTS: S0 - S3 = 4.5 V, S1 = S2 = M = 0 V

PARAMETER	INPUT UNDER TEST	OTHER INPUT SAME BIT		OTHER DATA INPUTS		OUTPUT UNDER TEST	OUTPUT WAVEFORM (See Note 4)
		APPLY 4.5 V	APPLY GND	APPLY 4.5 V	APPLY GND		
1PLH 1PHL	$\bar{A}_1$	B	None	Remaining A and B	$C_n$	$\bar{F}_1$	In-Phase
1PLH 1PHL	$\bar{B}_1$	A	None	Remaining A and B	$C_n$	$\bar{F}_1$	In-Phase
1PLH 1PHL	A <sub>1</sub>	$\bar{B}_1$	None	None	Remaining A and B, C <sub>n</sub>	$\bar{P}$	In-Phase
1PLH 1PHL	B <sub>1</sub>	A <sub>1</sub>	None	None	Remaining A and B, C <sub>n</sub>	P	In-Phase
1PLH 1PHL	$\bar{A}_1$	None	B	Remaining B	Remaining A, C <sub>n</sub>	$\bar{G}$	In-Phase
1PLH 1PHL	$\bar{B}_1$	None	$\bar{A}_1$	Remaining B	Remaining A, C <sub>n</sub>	$\bar{G}$	In-Phase
1PLH 1PHL	C <sub>n</sub>	None	None	All $\bar{A}$	All $\bar{B}$	Any F or C <sub>11-4</sub>	In-Phase
1PLH 1PHL	A <sub>1</sub>	None	B <sub>1</sub>	Remaining B	Remaining A, C <sub>n</sub>	C <sub>11-4</sub>	Out-of-Phase
1PLH 1PHL	$\bar{B}_1$	None	$\bar{A}_1$	Remaining B	Remaining A, C <sub>n</sub>	C <sub>11-4</sub>	Out-of-Phase

DIFF MODE TEST TABLE

FUNCTION INPUTS: S1 = S2 = 4.5 V, S0 = S3 = M = 0 V

PARAMETER	INPUT UNDER TEST	OTHER INPUT SAME BIT		OTHER DATA INPUTS		OUTPUT UNDER TEST	OUTPUT WAVEFORM (See Note 4)
		APPLY 4.5 V	APPLY GND	APPLY 4.5 V	APPLY GND		
1PLH 1PHL	$\bar{A}_1$	None	$\bar{B}_1$	Remaining A	Remaining B, C <sub>n</sub>	$\bar{F}_1$	In-Phase
1PLH 1PHL	B	A	None	Remaining A	Remaining B, C <sub>n</sub>	$\bar{F}_1$	Out-of-Phase
1PLH 1PHL	A	None	$\bar{B}_1$	None	Remaining A and B, C <sub>n</sub>	P	In-Phase
1PLH 1PHL	B	$\bar{A}_1$	None	None	Remaining A and B, C <sub>n</sub>	$\bar{P}$	Out-of-Phase
1PLH 1PHL	$\bar{A}_1$	$\bar{B}_1$	None	None	Remaining A and B, C <sub>n</sub>	$\bar{G}$	In-Phase
1PLH 1PHL	B <sub>1</sub>	None	$\bar{A}_1$	None	Remaining A and B, C <sub>n</sub>	G	Out-of-Phase
1PLH 1PHL	A <sub>1</sub>	None	B	Remaining A	Remaining B, C <sub>n</sub>	A - B	In-Phase
1PLH 1PHL	$\bar{B}_1$	$\bar{A}_1$	None	Remaining A	Remaining B, C <sub>n</sub>	A - B	Out-of-Phase
1PLH 1PHL	C <sub>11</sub>	None	None	All A and B	None	C <sub>11-4</sub> or any F	In-Phase
1PLH 1PHL	$\bar{A}$	$\bar{B}_1$	None	None	Remaining A, B, C <sub>n</sub>	C <sub>11-4</sub>	Out-of-Phase
1PLH 1PHL	$\bar{B}_1$	None	$\bar{A}_1$	None	Remaining A, B, C <sub>n</sub>	C <sub>11-4</sub>	In-Phase

LOGIC MODE TEST TABLE

FUNCTION INPUTS: S1 = S2 = M = 4.5 V, S0 = S3 = 0 V

PARAMETER	INPUT UNDER TEST	OTHER INPUT SAME BIT		OTHER DATA INPUTS		OUTPUT UNDER TEST	OUTPUT WAVEFORM (See Note 4)
		APPLY 4.5 V	APPLY GND	APPLY 4.5 V	APPLY GND		
1PLH 1PHL	$\bar{A}_1$	B	None	None	Remaining A and B, C <sub>n</sub>	$\bar{F}_1$	Out-of-Phase
1PLH 1PHL	$\bar{B}_1$	$\bar{A}_1$	None	None	Remaining A and B, C <sub>n</sub>	$\bar{F}_1$	Out-of-Phase

NOTE 4: See General Information Section for load currents and voltage waveforms.

3

TTL DEVICES

This datasheet has been downloaded from:

[www.DatasheetCatalog.com](http://www.DatasheetCatalog.com)

Datasheets for electronic components.

# Texas Instruments

<http://www.ti.com>

This file is the datasheet for the following electronic components:

SN74181 - <http://www.ti.com/product/sn74181?HQS=TI-null-null-dscatalog-df-pf-null-ww>