

**RADIATION HARDENED
 PNP SILICON SWITCHING TRANSISTOR**
Qualified per MIL-PRF-19500/357

DEVICES

2N3634	2N3635	2N3636	2N3637
2N3634L	2N3635L	2N3636L	2N3637L
2N3634UB	2N3635UB	2N3636UB	2N3637UB

LEVELS

JANSM – 3K Rads (Si)
JANSD – 10K Rads (Si)
JANSP – 30K Rads (Si)
JANSL – 50K Rads (Si)
JANSR – 100K Rads (Si)

ABSOLUTE MAXIMUM RATINGS ($T_C = +25^\circ\text{C}$ unless otherwise noted)

Parameters / Test Conditions	Symbol	2N3634*	2N3636*	Unit
		2N3635*	2N3637*	
Collector-Emitter Voltage	V_{CEO}	140	175	Vdc
Collector-Base Voltage	V_{CBO}	140	175	Vdc
Emitter-Base Voltage	V_{EBO}	5.0	5.0	Vdc
Collector Current	I_C	1.0	1.0	A _{dc}
Total Power Dissipation	@ $T_A = +25^\circ\text{C}$	1.0		W
	@ $T_C = +25^\circ\text{C}$	5.0		W
	UB: @ $T_C = +25^\circ\text{C}$	1.5		W
Operating & Storage Junction Temperature Range	T_J, T_{stg}	-65 to +200		$^\circ\text{C}$

* Electrical characteristics for “L” suffix devices are identical to the “non L” corresponding devices.

** Consult 19500/357 for De-Rating curves.

ELECTRICAL CHARACTERISTICS ($T_A = +25^\circ\text{C}$, unless otherwise noted)

Parameters / Test Conditions	Symbol	Min.	Max.	Unit
OFF CHARACTERISTICS				
Collector-Emitter Breakdown Voltage $I_C = 10\text{mA}_{dc}$	$V_{(BR)CEO}$	140		Vdc
2N3634, 2N3635 2N3636, 2N3637		175		
Collector-Base Cutoff Current $V_{CB} = 100\text{Vdc}$	I_{CBO}		100	ηA_{dc}
$V_{CB} = 140\text{Vdc}$		2N3634, 2N3635	10	μA_{dc}
$V_{CB} = 175\text{Vdc}$		2N3636, 2N3637	10	μA_{dc}
Emitter-Base Cutoff Current $V_{EB} = 3.0\text{Vdc}$	I_{EBO}		50	ηA_{dc}
$V_{EB} = 5.0\text{Vdc}$			10	μA_{dc}
Collector-Emitter cutoff Current $V_{CE} = 100\text{Vdc}$	I_{CEO}		10	μA_{dc}

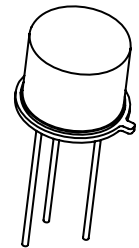

TO-5*
 2N3634L, 2N3635L
 2N3636L, 2N3637L

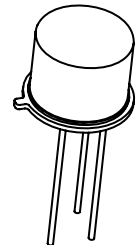

TO-39* (TO-205AD)
 2N3634, 2N3635
 2N3636, 2N3637

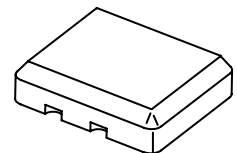

3 PIN
 2N3634UB, 2N3635UB
 2N3636UB, 2N3637UB

ELECTRICAL CHARACTERISTICS ($T_A = +25^\circ\text{C}$, unless otherwise noted)

Parameters / Test Conditions	Symbol	Min.	Max.	Unit
ON CHARACTERISTICS ⁽¹⁾				
Forward-Current Transfer Ratio $I_C = 0.1\text{mA dc}, V_{CE} = 10\text{V dc}$ $I_C = 1.0\text{mA dc}, V_{CE} = 10\text{V dc}$ $I_C = 10\text{mA dc}, V_{CE} = 10\text{V dc}$ $I_C = 50\text{mA dc}, V_{CE} = 10\text{V dc}$ $I_C = 150\text{mA dc}, V_{CE} = 10\text{V dc}$ 2N3634, 2N3636	h_{FE}	25	150	
$I_C = 0.1\text{mA dc}, V_{CE} = 10\text{V dc}$ $I_C = 1.0\text{mA dc}, V_{CE} = 10\text{V dc}$ $I_C = 10\text{mA dc}, V_{CE} = 10\text{V dc}$ $I_C = 50\text{mA dc}, V_{CE} = 10\text{V dc}$ $I_C = 150\text{mA dc}, V_{CE} = 10\text{V dc}$ 2N3635, 2N3637		45		
		50		
		50		
		30		
		55		
		90		
		100		
		100		
		60		
Collector-Emitter Saturation Voltage $I_C = 10\text{mA dc}, I_B = 1.0\text{mA dc}$ $I_C = 50\text{mA dc}, I_B = 5.0\text{mA dc}$	$V_{CE(sat)}$		0.3 0.6	Vdc
Base-Emitter Saturation Voltage $I_C = 10\text{mA dc}, I_B = 1.0\text{mA dc}$ $I_C = 50\text{mA dc}, I_B = 5.0\text{mA dc}$	$V_{BE(sat)}$	0.65	0.8 0.9	Vdc

DYNAMIC CHARACTERISTICS

Forward Current Transfer Ratio $I_C = 30\text{mA dc}, V_{CE} = 30\text{V dc}, f = 100\text{MHz}$ 2N3634, 2N3636 2N3635, 2N3637	$ h_{fe} $	1.5 2.0	8.0 8.5	
Forward Current Transfer Ratio $I_C = 10\text{mA dc}, V_{CE} = 10\text{V dc}, f = 1.0\text{kHz}$ 2N3634, 2N3636 2N3635, 2N3637	h_{fe}	40 80	160 320	
Small-Signal Short-Circuit Input Impedance $I_C = 10\text{mA dc}, V_{CE} = 10\text{V dc}, f = 1.0\text{kHz}$ 2N3634, 2N3636 2N3635, 2N3637	h_{ie}	100 200	600 1200	Ω
Small-Signal Open-Circuit Input Impedance $I_C = 10\text{mA dc}, V_{CE} = 10\text{V dc}, f = 1.0\text{kHz}$	h_{oe}		200	μs
Output Capacitance $V_{CB} = 20\text{V dc}, I_E = 0, 100\text{ kHz} \leq f \leq 1.0\text{MHz}$	C_{obo}		10	pF
Input Capacitance $V_{EB} = 1.0\text{V dc}, I_C = 0, 100\text{ kHz} \leq f \leq 1.0\text{MHz}$	C_{ibo}		75	pF
Noise Figure $V_{CE} = 10\text{V dc}, I_C = 0.5\text{mA dc}, R_g = 1.0\text{k}\Omega$ $f = 100\text{Hz}$ $f = 1.0\text{kHz}$ $f = 10\text{kHz}$	NF		5.0 3.0 3.0	dB

(1) Pulse Test: Pulse Width = 300 μs , Duty Cycle $\leq 2.0\%$



TECHNICAL DATA SHEET

6 Lake Street, Lawrence, MA 01841
1-800-446-1158 / (978) 620-2600 / Fax: (978) 689-0803
Website: <http://www.microsemi.com>

SAFE OPERATING AREA

DC Tests

$T_C = 25^\circ\text{C}$, 1 Cycle, $t = 1.0\text{s}$

Test 1

$V_{CE} = 100\text{Vdc}$, $I_C = 30\text{mA}$

2N3634, 2N3635

$V_{CE} = 130\text{Vdc}$, $I_C = 20\text{mA}$

2N3636, 2N3637

Test 2

$V_{CE} = 50\text{Vdc}$, $I_C = 95\text{mA}$

Test 3

$V_{CE} = 5.0\text{Vdc}$, $I_C = 1.0\text{A}$

PACKAGE DIMENSIONS

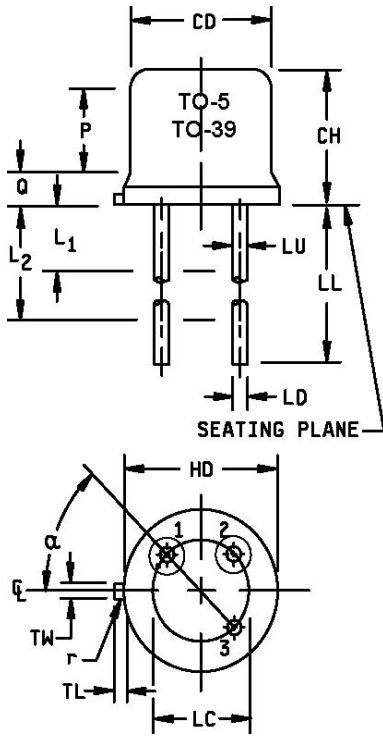

Ltr	Dimensions				Notes
	Inches		Millimeters		
	Min	Max	Min	Max	
CD	.305	.335	7.75	8.51	
CH	.240	.260	6.10	6.60	
HD	.335	.370	8.51	9.40	
LC	.200 TYP		5.08 TYP		7
LD	.016	.021	0.41	0.53	6
LL	See notes 7, 9, and 10				
LU	.016	.019	0.41	0.48	7
L1		.050		1.27	7
L2	.250		6.35		7
P	.100		2.54		5
Q		.050		1.27	
r		.010		0.254	8
TL	.029	.045	0.74	1.14	4
TW	.028	.034	0.71	0.86	3
α	45° TP		45° TP		6
Term 1	Emitter				
Term 2	Base				
Term 3	Collector				

NOTES:

- Dimensions are in inches.
- Millimeters are given for general information only.
- Beyond r maximum, TW must be held to a minimum length of .021 inch (0.53 mm).
- TL measured from maximum HD.
- CD shall not vary more than ± 0.010 inch (0.25 mm) in zone P. This zone is controlled for automatic handling.
- Leads at gauge plane .054 - .055 inch (1.37 - 1.40 mm) below seating plane shall be within .007 inch (0.18 mm) radius of true position (TP) at a maximum material condition (MMC) relative to the tab at MMC. The device may be measured by direct methods or by gauge and gauging procedure.
- LU applies between L1 and L2. LD applies between L2 and L minimum. Diameter is uncontrolled in L1 and beyond LL minimum.
- r (radius) applies to both inside corners of tab.
- For transistor types 2N3634 through 2N3637, LL is .500 inch (12.70 mm) minimum, and .750 inch (19.05 mm) maximum (TO-39).
- For transistor types 2N3634L through 2N3637L, LL is 1.500 inches (38.10 mm) minimum, and 1.750 inches (44.45 mm) maximum (TO-5).
- In accordance with ASME Y14.5M, diameters are equivalent to ϕx symbology.

FIGURE 1: Physical dimensions (TO-5 and TO-39)

6 Lake Street, Lawrence, MA 01841
 1-800-446-1158 / (978) 620-2600 / Fax: (978) 689-0803
 Website: <http://www.microsemi.com>

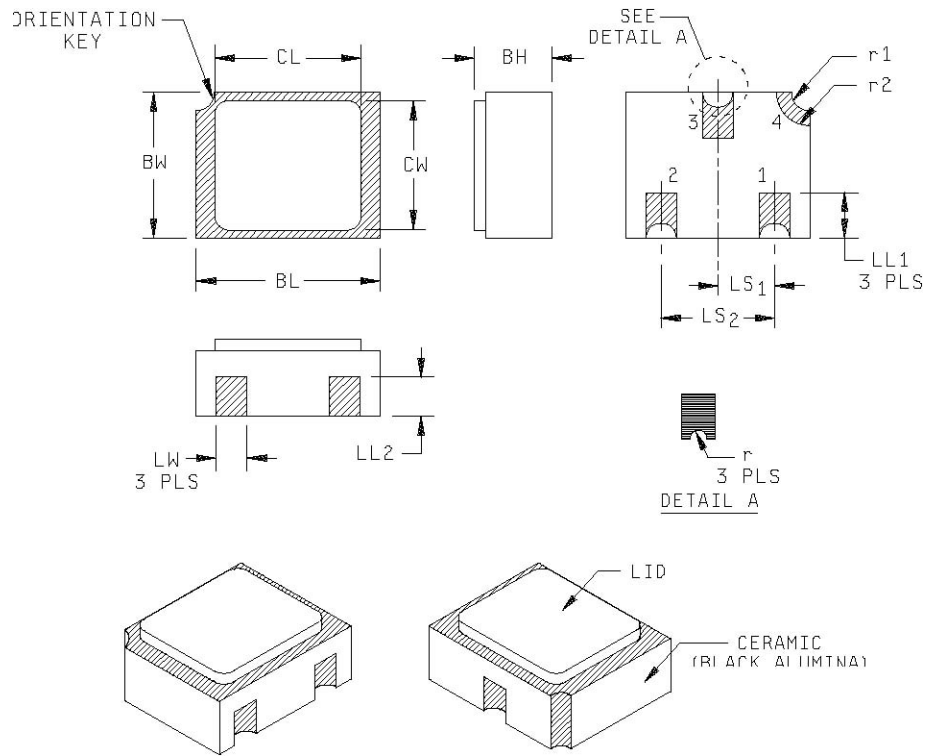

NOTES:

1. Dimensions are in inches.
2. Millimeters are given for general information only.
3. Hatched areas on package denote metallized areas.
4. Pad 1 = Base, Pad 2 = Emitter, Pad 3 = Collector, Pad 4 = Shielding connected to the lid.
5. In accordance with ASME Y14.5M, diameters are equivalent to ϕx symbology

Ltr	Dimensions				Notes
	Inches		Millimeters		
	Min	Max	Min	Max	
BH	.046	.056	1.17	1.42	
BL	.115	.128	2.92	3.25	
BW	.085	.108	2.16	2.74	
CL		.128		3.25	
CW		.108		2.74	
LL1	.022	.038	0.56	0.96	
LL2	.017	.035	0.43	0.89	
LS1	.036	.040	0.91	1.02	
LS2	.071	.079	1.81	2.01	
LW	.016	.024	0.41	0.61	
r		.008		.203	
r1		.012		.305	
r2		.022		.559	

FIGURE 2: Physical dimensions, surface mount 2N3634UB through 2N3637UB (UB version).