

## ADXL150/ADXL250

### FEATURES

**Complete Acceleration Measurement System  
on a Single Monolithic IC**

**80 dB Dynamic Range**

**Pin Programmable ±50 g or ±25 g Full Scale**

**Low Noise: 1 mg/√Hz Typical**

**Low Power: <2 mA per Axis**

**Supply Voltages as Low as 4 V**

**2-Pole Filter On-Chip**

**Ratiometric Operation**

**Complete Mechanical & Electrical Self-Test**

**Dual & Single Axis Versions Available**

**Surface Mount Package**

### GENERAL DESCRIPTION

The ADXL150 and ADXL250 are third generation ±50 g surface micromachined accelerometers. These improved replacements for the ADXL50 offer lower noise, wider dynamic range, reduced power consumption and improved zero g bias drift.

The ADXL150 is a single axis product; the ADXL250 is a fully integrated dual axis accelerometer with signal conditioning on a single monolithic IC, the first of its kind available on the commercial market. The two sensitive axes of the ADXL250 are orthogonal (90°) to each other. Both devices have their sensitive axes in the same plane as the silicon chip.

The ADXL150/ADXL250 offer lower noise and improved signal-to-noise ratio over the ADXL50. Typical S/N is 80 dB, allowing resolution of signals as low as 10 mg, yet still providing a ±50 g full-scale range. Device scale factor can be increased from 38 mV/g to 76 mV/g by connecting a jumper between V<sub>OUT</sub> and the offset null pin. Zero g drift has been reduced to 0.4 g over the industrial temperature range, a 10× improvement over the ADXL50. Power consumption is a modest 1.8 mA per axis. The scale factor and zero g output level are both

### FUNCTIONAL BLOCK DIAGRAMS

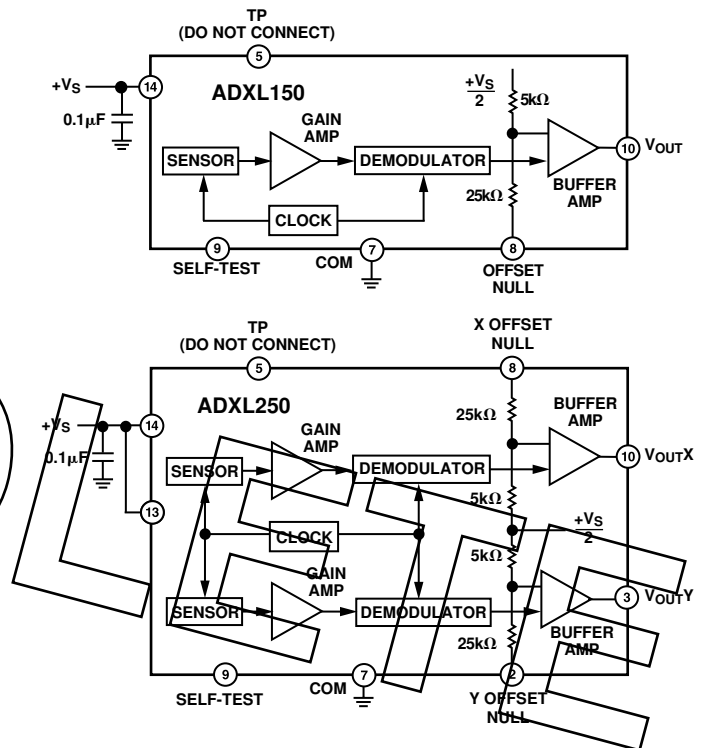

ratiometric to the power supply, eliminating the need for a voltage reference when driving ratiometric A/D converters such as those found in most microprocessors. A power supply bypass capacitor is the only external component needed for normal operation.

The ADXL150/ADXL250 are available in a hermetic 14-lead surface mount cerpac package specified over the 0°C to +70°C commercial and -40°C to +85°C industrial temperature ranges. Contact factory for availability of devices specified over automotive and military temperature ranges.

*i*MEMS is a registered trademark of Analog Devices, Inc.

### REV. 0

Information furnished by Analog Devices is believed to be accurate and reliable. However, no responsibility is assumed by Analog Devices for its use, nor for any infringements of patents or other rights of third parties which may result from its use. No license is granted by implication or otherwise under any patent or patent rights of Analog Devices.

# ADXL150/ADXL250—SPECIFICATIONS (T<sub>A</sub> = +25°C for J Grade, T<sub>A</sub> = -40°C to +85°C for A Grade, V<sub>S</sub> = +5.00 V, Acceleration = Zero g, unless otherwise noted)

Parameter	Conditions	ADXL150JQC/AQC			ADXL250JQC/AQC			Units
		Min	Typ	Max	Min	Typ	Max	
<b>SENSOR</b>								
Guaranteed Full-Scale Range		±40	±50		±40	±50		g
Nonlinearity			0.2			0.2		% of FS
Package Alignment Error <sup>1</sup>			±1			±1		Degrees
Sensor-to-Sensor Alignment Error						±0.1		Degrees
Transverse Sensitivity <sup>2</sup>			±2			±2		%
<b>SENSITIVITY</b>								
Sensitivity (Ratiometric) <sup>3</sup>	Y Channel X Channel	33.0	38.0	43.0	33.0	38.0	43.0	mV/g
Sensitivity Drift Due to Temperature	Delta from 25°C to T <sub>MIN</sub> or T <sub>MAX</sub>		±0.5			±0.5		%
<b>ZERO g BIAS LEVEL</b>								
Output Bias Voltage <sup>4</sup>		V <sub>S</sub> /2 - 0.35	V <sub>S</sub> /2	V <sub>S</sub> /2 + 0.35	V <sub>S</sub> /2 - 0.35	V <sub>S</sub> /2	V <sub>S</sub> /2 + 0.35	V
Zero g Drift Due to Temperature	Delta from 25°C to T <sub>MIN</sub> or T <sub>MAX</sub>		0.2			0.3		g
<b>ZERO-g OFFSET ADJUSTMENT</b>								
Voltage Gain	Delta V <sub>OUT</sub> /Delta V <sub>OS PIN</sub>	0.45	0.50	0.55	0.45	0.50	0.55	V/V
Input Impedance		20	30		20	30		kΩ
<b>NOISE PERFORMANCE</b>								
Noise Density <sup>5</sup>			1	2.5		1	2.5	mg/√Hz
Clock Noise			5			5		mV p-p
<b>FREQUENCY RESPONSE</b>								
-3 dB Bandwidth		900	1000		900	1000		Hz
Bandwidth Temperature Drift	T <sub>MIN</sub> to T <sub>MAX</sub>		50			50		Hz
Sensor Resonant Frequency	Q = 5		24			24		kHz
<b>SELF-TEST</b>								
Output Change <sup>6</sup>	ST Pin from Logic "0" to "1"	0.25	0.40	0.60	0.25	0.40	0.60	V
Logic "1" Voltage		V <sub>S</sub> - 1			V <sub>S</sub> - 1			V
Logic "0" Voltage				1.0			1.0	V
Input Resistance	To Common	30	50		30	50		kΩ
<b>OUTPUT AMPLIFIER</b>								
Output Voltage Swing	I <sub>OUT</sub> = ±100 μA	0.25		V <sub>S</sub> - 0.25	0.25		V <sub>S</sub> - 0.25	V
Capacitive Load Drive		1000			1000			pF
<b>POWER SUPPLY (V<sub>S</sub>)<sup>7</sup></b>								
Functional Voltage Range		4.0		6.0	4.0		6.0	V
Quiescent Supply Current	ADXL150 ADXL250 (Total 2 Channels)		1.8	3.0		3.5	5.0	mA
<b>TEMPERATURE RANGE</b>								
Operating Range J		0		+70	0		+70	°C
Specified Performance A		-40		+85	-40		+85	°C

## NOTES

<sup>1</sup>Alignment error is specified as the angle between the true axis of sensitivity and the edge of the package.

<sup>2</sup>Transverse sensitivity is measured with an applied acceleration that is 90 degrees from the indicated axis of sensitivity.

<sup>3</sup>Ratiometric: V<sub>OUT</sub> = V<sub>S</sub>/2 + (Sensitivity × V<sub>S</sub>/5 V × a) where a = applied acceleration in g<sub>s</sub>, and V<sub>S</sub> = supply voltage. See Figure 21. Output scale factor can be doubled by connecting V<sub>OUT</sub> to the offset null pin.

<sup>4</sup>Ratiometric, proportional to V<sub>S</sub>/2. See Figure 21.

<sup>5</sup>See Figure 11 and Device Bandwidth vs. Resolution section.

<sup>6</sup>Self-test output varies with supply voltage.

<sup>7</sup>When using ADXL250, both Pins 13 and 14 must be connected to the supply for the device to function.

Specifications subject to change without notice.

# ADXL150/ADXL250

## ABSOLUTE MAXIMUM RATINGS\*

Acceleration (Any Axis, Unpowered for 0.5 ms) . . . . .	2000 g
Acceleration (Any Axis, Powered for 0.5 ms) . . . . .	500 g
+V <sub>S</sub> . . . . .	-0.3 V to +7.0 V
Output Short Circuit Duration (V <sub>OUT</sub> , V <sub>REF</sub> Terminals to Common) . . . . .	Indefinite
Operating Temperature . . . . .	-55°C to +125°C
Storage Temperature . . . . .	-65°C to +150°C

\*Stresses above those listed under Absolute Maximum Ratings may cause permanent damage to the device. This is a stress rating only; the functional operation of the device at these or any other conditions above those indicated in the operational sections of this specification is not implied. Exposure to absolute maximum rating conditions for extended periods may affect device reliability.

## Package Characteristics

Package	$\theta_{JA}$	$\theta_{JC}$	Device Weight
14-Lead Cerpac	110°C/W	30°C/W	5 Grams

## ORDERING GUIDE

Model	Temperature Range
ADXL150JQC	0°C to +70°C
ADXL150AQC	-40°C to +85°C
ADXL250JQC	0°C to +70°C
ADXL250AQC	-40°C to +85°C

Drops onto hard surfaces can cause shocks of greater than 2000 g and exceed the absolute maximum rating of the device. Care should be exercised in handling to avoid damage.

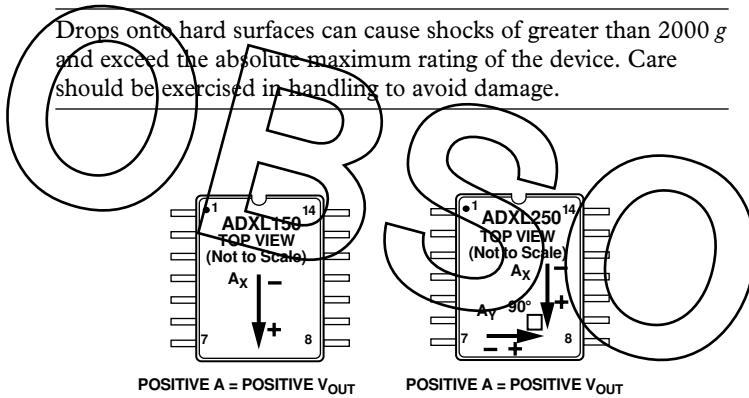
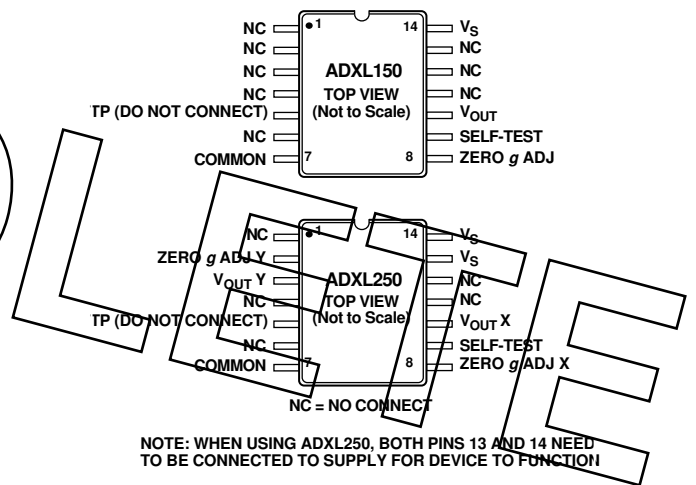

Figure 1. ADXL150 and ADXL250 Sensitive Axis Orientation

## PIN CONNECTIONS



## CAUTION

ESD (electrostatic discharge) sensitive device. Electrostatic charges as high as 4000 V readily accumulate on the human body and test equipment and can discharge without detection. Although the ADXL150/ADXL250 feature proprietary ESD protection circuitry, permanent damage may occur on devices subjected to high energy electrostatic discharges. Therefore, proper ESD precautions are recommended to avoid performance degradation or loss of functionality.



# ADXL150/ADXL250

## GLOSSARY OF TERMS

**Acceleration:** Change in velocity per unit time.

**Acceleration Vector:** Vector describing the net acceleration acting upon the ADXL150/ADXL250.

**g:** A unit of acceleration equal to the average force of gravity occurring at the earth's surface. A  $g$  is approximately equal to 32.17 feet/s<sup>2</sup> or 9.807 meters/s<sup>2</sup>.

**Nonlinearity:** The maximum deviation of the ADXL150/ADXL250 output voltage from a best fit straight line fitted to a plot of acceleration vs. output voltage, calculated as a % of the full-scale output voltage (at 50  $g$ ).

**Resonant Frequency:** The natural frequency of vibration of the ADXL150/ADXL250 sensor's central plate (or "beam"). At its resonant frequency of 24 kHz, the ADXL150/ADXL250's moving center plate has a slight peak in its frequency response.

**Sensitivity:** The output voltage change per  $g$  unit of acceleration applied, specified at the V<sub>OUT</sub> pin in mV/g.

**Total Alignment Error:** Net misalignment of the ADXL150/ADXL250's on-chip sensor and the measurement axis of the application. This error includes errors due to sensor die alignment to the package, and any misalignment due to installation of the sensor package in a circuit board or module.

**Transverse Acceleration:** Any acceleration applied 90° to the axis of sensitivity.

**Transverse Sensitivity Error:** The percent of a transverse acceleration that appears at V<sub>OUT</sub>.

**Transverse Axis:** The axis perpendicular (90°) to the axis of sensitivity.

**Zero g Bias Level:** The output voltage of the ADXL150/ADXL250 when there is no acceleration (or gravity) acting upon the axis of sensitivity. The output offset is the difference between the actual zero  $g$  bias level and (V<sub>S</sub>/2).

## Polarity of the Acceleration Output

The polarity of the ADXL150/ADXL250 output is shown in Figure 1. When its sensitive axis is oriented to the earth's gravity (and held in place), it will experience an acceleration of +1  $g$ . This corresponds to a change of approximately +38 mV at the output pin. Note that the polarity will be reversed if the package is rotated 180°. The figure shows the ADXL250 oriented so that its "X" axis measures +1  $g$ . If the package is rotated 90° clockwise (Pin 14 up, Pin 1 down), the ADXL250's "Y" axis will now measure +1  $g$ .

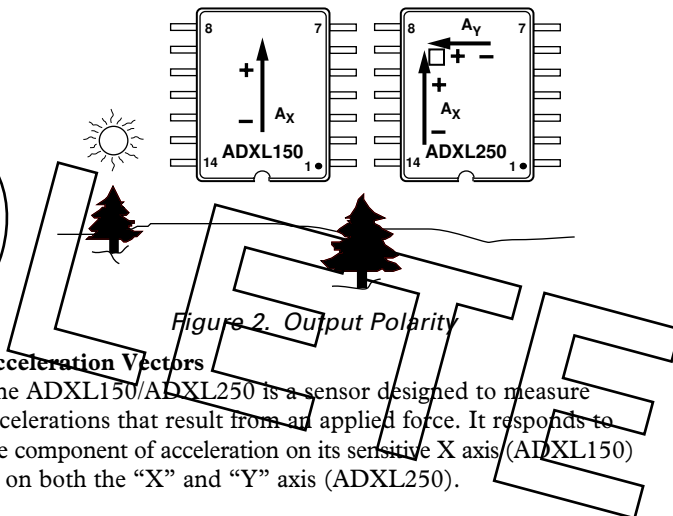

Typical Characteristics (@+5 V dc, +25°C with a 38 mV/g Scale Factor unless otherwise noted)

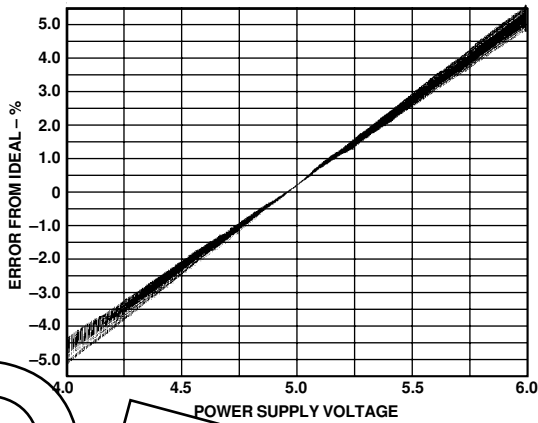

Figure 3. Typical Sensitivity Error from Ideal Ratiometric Response for a Number of Units

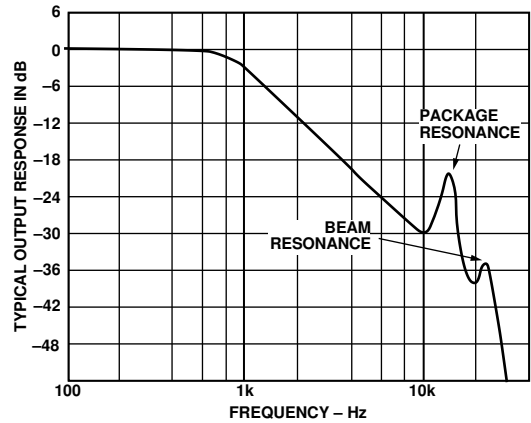

Figure 6. Typical Output Response vs. Frequency of ADXL150/ADXL250 on a PC Board that Has Been Conformally Coated

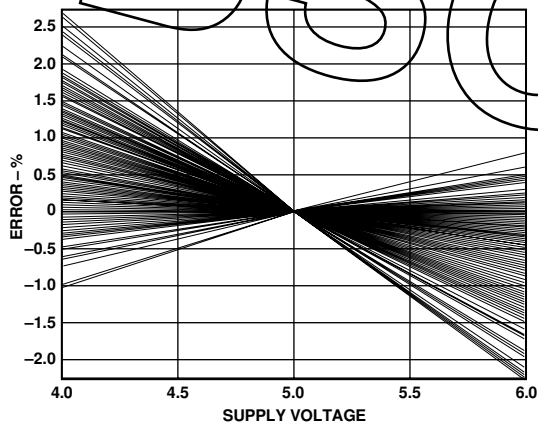

Figure 4. Offset Error of Zero g Level from Ideal  $V_S/2$  Response as a Percent of Full-Scale for a Number of Units

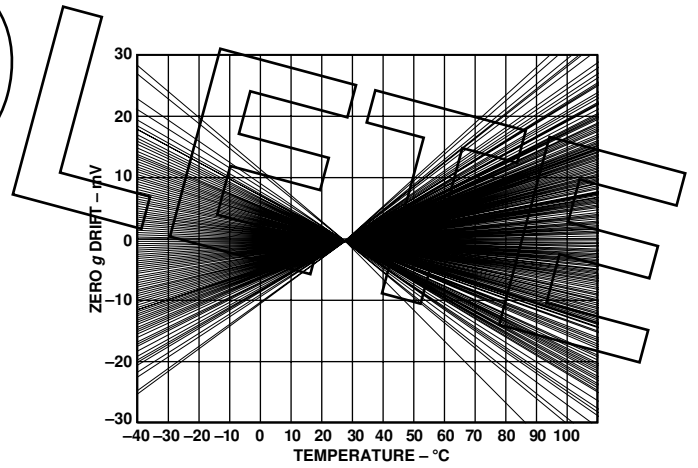

Figure 7. Typical Zero g Drift for a Number of Units

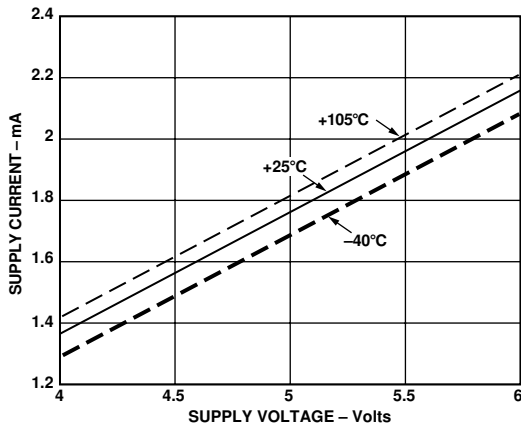

Figure 5. Typical Supply Current vs. Supply Voltage

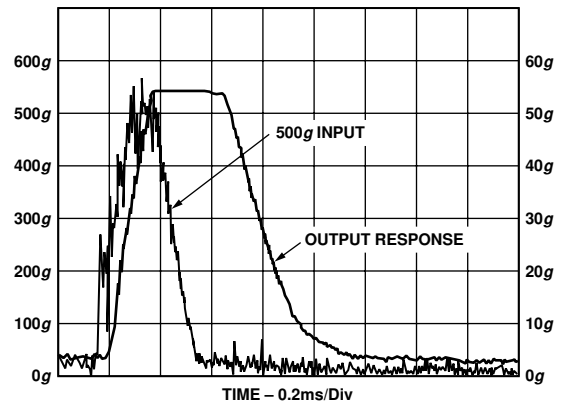

Figure 8. Typical 500 g Step Recovery at the Output

# ADXL150/ADXL250

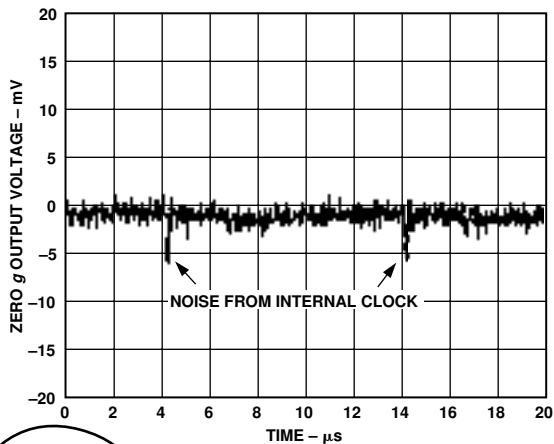

Figure 9. Typical Output Noise Voltage with Spikes Generated by Internal Clock

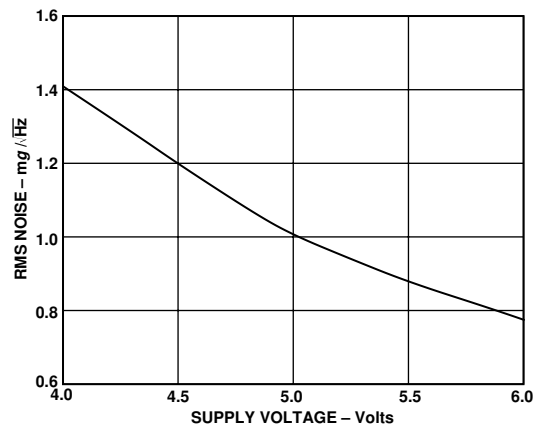

Figure 12. Noise vs. Supply Voltage

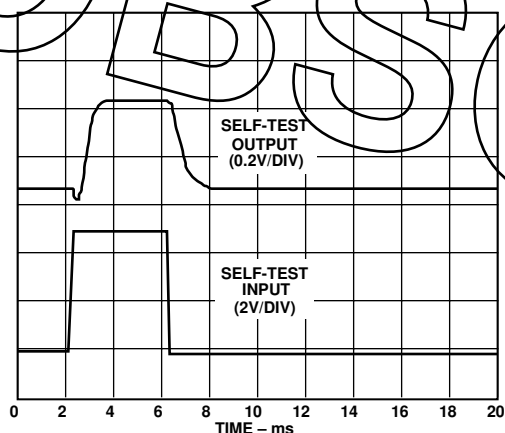

Figure 10. Typical Self-Test Response

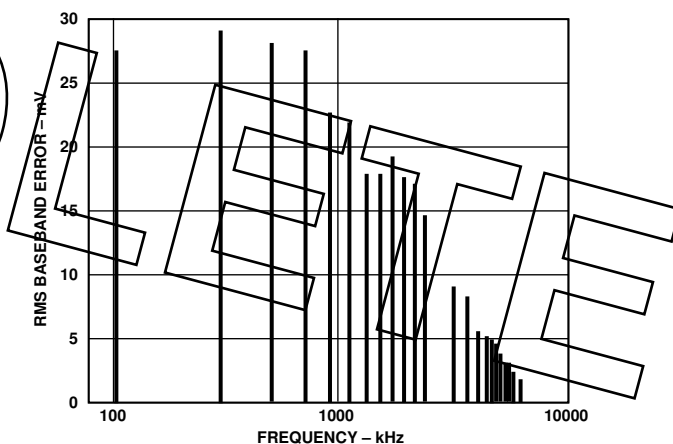

Figure 13. Baseband Error Graph

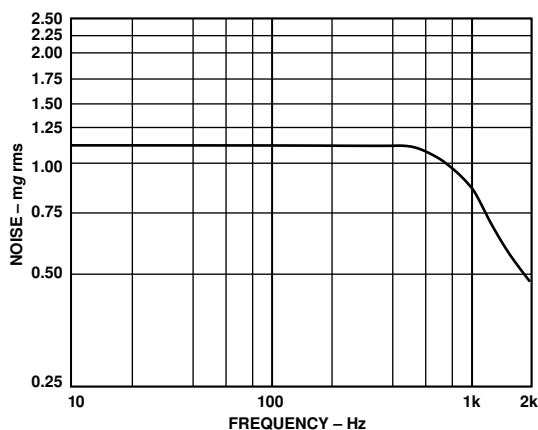

Figure 11. Noise Spectral Density

Figure 13 shows the mV rms error in the output signal if there is a noise on the power supply pin of 1 mV rms at the internal clock frequency or its odd harmonics. This is a baseband noise and can be at any frequency in the 1 kHz passband or at dc.

## THEORY OF OPERATION

The ADXL150 and ADXL250 are fabricated using a proprietary surface micromachining process that has been in high volume production since 1993. The fabrication technique uses standard integrated circuit manufacturing methods enabling all the signal processing circuitry to be combined on the same chip with the sensor.

The surface micromachined sensor element is made by depositing polysilicon on a sacrificial oxide layer that is then etched away leaving the suspended sensor element. Figure 14 is a simplified view of the sensor structure. The actual sensor has 42 unit cells for sensing acceleration. The differential capacitor sensor is composed of fixed plates and moving plates attached to the beam that moves in response to acceleration. Movement of the beam changes the differential capacitance, which is measured by the on chip circuitry.

The sensor has 12-unit capacitance cells for electrostatically forcing the beam during a self-test. Self-test is activated by the user with a logic high on the self-test input pin. During a logic high, an electrostatic force acts on the beam equivalent to approximately 20% of full-scale acceleration input, and thus a proportional voltage change appears on the output pin. When activated, the self-test feature exercises both the entire mechanical structure and the electrical circuitry.

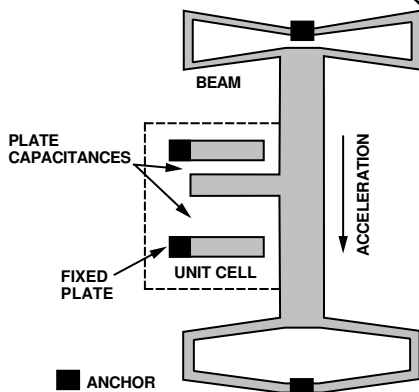

Figure 14. Simplified View of Sensor Under Acceleration

All the circuitry needed to drive the sensor and convert the capacitance change to voltage is incorporated on the chip requiring no external components except for standard power supply decoupling. Both sensitivity and the zero-g value are ratiometric to the supply voltage, so that ratiometric devices following the accelerometer (such as an ADC, etc.) will track the accelerometer if the supply voltage changes. The output voltage ( $V_{OUT}$ ) is a function of both the acceleration input ( $a$ ) and the power supply voltage ( $V_S$ ) as follows:

$$V_{OUT} = V_S/2 - (\text{Sensitivity} \times \frac{V_S}{5V} \times a)$$

Both the ADXL150 and ADXL250 have a 2-pole Bessel switched-capacitor filter. Bessel filters, sometimes called linear phase filters, have a step response with minimal overshoot and a maximally flat group delay. The  $-3$  dB frequency of the poles is preset at the factory to 1 kHz. These filters are also completely self-contained and buffered, requiring no external components.

## MEASURING ACCELERATIONS LESS THAN 50 g

The ADXL150/ADX250 require only a power supply bypass capacitor to measure  $\pm 50$  g accelerations. For measuring  $\pm 50$  g accelerations, the accelerometer may be directly connected to an ADC (see Figure 25). The device may also be easily modified to measure lower g signals by increasing its output scale factor.

The scale factor of an accelerometer specifies the voltage change of the output per g of applied acceleration. This should not be confused with its resolution. The resolution of the device is the lowest g level the accelerometer is capable of measuring. Resolution is principally determined by the device noise and the measurement bandwidth.

The zero g bias level is simply the dc output level of the accelerometer when it is not in motion or being acted upon by the earth's gravity.

### Pin Programmable Scale Factor Option

In its normal state, the ADXL150/ADX250's buffer amplifier provides an output scale factor of 38 mV/g, which is set by an internal voltage divider. This gives a full-scale range of  $\pm 50$  g and a nominal bandwidth of 1 kHz.

A factor-of-two increase in sensitivity can be obtained by connecting the  $V_{OUT}$  pin to the offset null pin, assuming that it is not needed for offset adjustment. This connection has the effect of reducing the internal feedback by a factor of two, doubling the buffer's gain. This increases the output scale factor to 76 mV/g and provides a  $\pm 25$  g full scale range.

Simultaneously, connecting these two pins also increases the amount of internal post filtering, reducing the noise floor and changing the nominal 3 dB bandwidth of the ADXL150/ADXL250 to 500 Hz. Note that the post filter's "Q" will also be reduced by a factor of  $\sqrt{2}$  from 0.58 (Bessel response) to a much gentler "Q" value of 0.41. The primary effect of this change in "Q" is only at frequencies within two octaves of the corner frequency; above this the two filter slopes are essentially the same. In applications where a flat response up to 500 Hz is needed, it is better to operate the device at 38 mV/g and use an external post filter. Note also that connecting  $V_{OUT}$  to the offset pin adds a 30 k $\Omega$  load from  $V_{OUT}$  to  $V_S/2$ . When swinging  $\pm 2$  V at  $V_{OUT}$ , this added load will consume  $\pm 60$   $\mu$ A of the ADXL150/ADXL250's 100  $\mu$ A (typical) output current drive.

# ADXL150/ADXL250

## Increasing the iMEMS Accelerometer's Output Scale Factor

Figure 15 shows the basic connections for using an external buffer amplifier to increase the output scale factor.

The output multiplied by the gain of the buffer, which is simply the value of resistor R3 divided by R1. Choose a convenient scale factor, keeping in mind that the buffer gain not only amplifies the signal, but any noise or drift as well. Too much gain can also cause the buffer to saturate and clip the output waveform.

Note that the “+” input of the external op amp uses the offset null pin of the ADXL150/ADXL250 as a reference, biasing the op amp at midsupply, saving two resistors and reducing power consumption. The offset null pin connects to the  $V_S/2$  reference point inside the accelerometer via 30 kΩ, so it is important not to load this pin with more than a few microamps.

It is important to use a single-supply or “rail-to-rail” op amp for the external buffer as it needs to be able to swing close to the supply and ground.

The circuit of Figure 15 is entirely adequate for many applications, but its accuracy is dependent on the pretrimmed accuracy of the accelerometer and this will vary by product type and grade.

For the highest possible accuracy, an external trim is recommended. As shown by Figure 20, this consists of a potentiometer, R1a, in series with a fixed resistor, R1b. Another option is to select resistor values after measuring the device's scale factor (see Figure 17).

### AC Coupling

If a dc (gravity) response is not required—for example in vibration measurement applications—ac coupling can be used between the accelerometer's output and the external op amp's input as shown in Figure 16. The use of ac coupling virtually eliminates any zero *g* drift and allows the maximum external amp gain without clipping.

Resistor R2 and capacitor C3 together form a high pass filter whose corner frequency is  $1/(2 \pi R2 C3)$ . This filter will reduce the signal from the accelerometer by 3 dB at the corner frequency, and it will continue to reduce it at a rate of 6 dB/octave (20 dB per decade) for signals below the corner frequency. Capacitor C3 should be a nonpolarized, low leakage type.

If ac coupling is used, the self-test feature must be monitored at the accelerometer's output rather than at the external amplifier output (since the self-test output is a dc voltage).

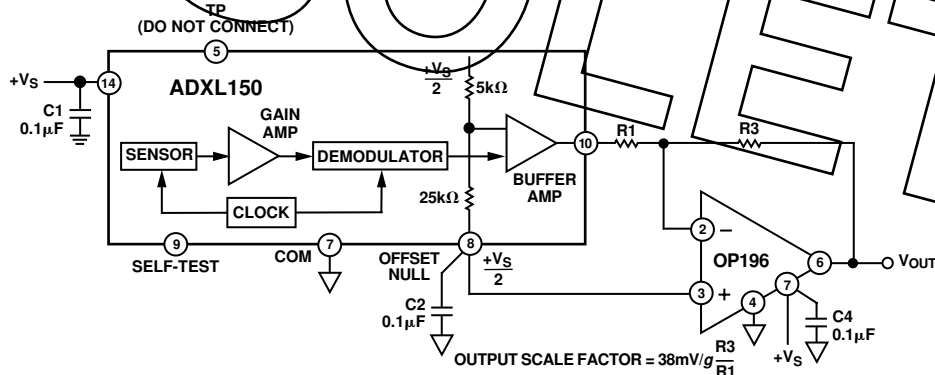
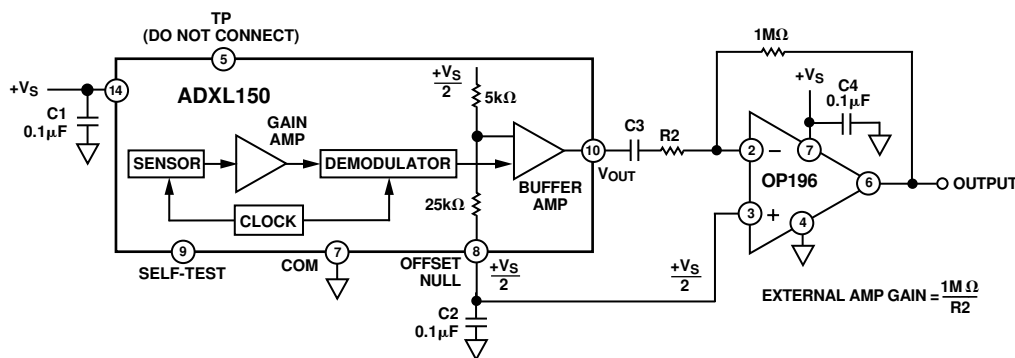

Figure 15. Using an External Op Amp to Increase Output Scale Factor



TYPICAL COMPONENT VALUES FOR AC COUPLED CIRCUIT

BUFFER GAIN	FS RANGE	R2	C3 VALUE FOR 3dB CORNER FREQ			
			1Hz	3Hz	10Hz	20Hz
2	±25g	1MΩ	0.15μF	0.05μF	0.015μF	0.0075μF
4	±12.5g	332kΩ	0.47μF	0.15μF	0.047μF	0.022μF
5	±10g	249kΩ	0.68μF	0.22μF	0.022μF	0.01μF

Figure 16. AC Coupled Connection Using an External Op Amp



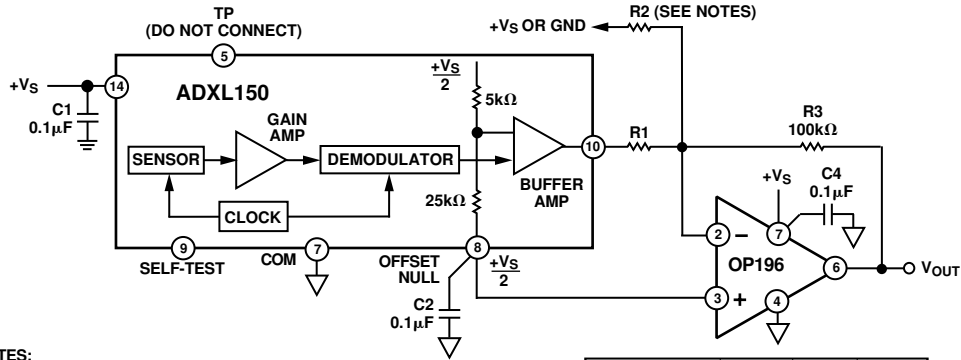

- NOTES:
- 0g "QUICK" CALIBRATION METHOD USING RESISTOR R2 AND A +5V SUPPLY.
  - (a) WITH ACCELEROMETER ORIENTED AWAY FROM EARTH'S GRAVITY (i.e., SIDWAYS), MEASURE PIN 10 OF THE ADXL150.
  - (b) CALCULATE THE OFFSET VOLTAGE THAT NEEDS TO BE NULLED:  
 $V_{OS} = (+2.5V - V_{PIN10}) / (R3/R1)$
  - (c)  $R2 = \frac{2.5V (R3)}{V_{OS}}$
  - (d) FOR  $V_{PIN10} > +2.5V$ , R2 CONNECTS TO GND.
  - (e) FOR  $V_{PIN10} < +2.5V$ , R2 CONNECTS TO +Vs.

DESIRED OUTPUT SCALE FACTOR	FS RANGE	EXT AMP GAIN	R1 VALUE
76mV/g	±25g	2.0	49.9kΩ
100mV/g	±20g	2.6	38.3kΩ
200mV/g	±10g	5.3	18.7kΩ
400mV/g	±5g	10.5	9.53kΩ

Figure 17. "Quick Zero g Calibration" Connection

### Adjusting the Zero g Bias Level

When a true dc (gravity) response is needed, the output from the accelerometer must be dc coupled to the external amplifier's input. For high gain applications, a zero g offset trim will also be needed. The external offset trim permits the user to set the zero g offset voltage to exactly +2.5 volts (allowing the maximum output swing from the external amplifier without clipping with a +5 supply).

With a dc coupled connection, any difference between the zero g output and +2.5 V will be amplified along with the signal. To obtain the exact zero g output desired or to allow the maximum output voltage swing from the external amplifier, the zero g offset will need to be externally trimmed using the circuit of Figure 20.

The external amplifier's maximum output swing should be limited to ±2 volts, which provides a safety margin of ±0.25 volts before clipping. With a +2.5 volt zero g level, the maximum gain will equal:

$$2 \text{ Volts}$$

$$38 \text{ mV/g Times the Max Applied Acceleration in g}$$

The device scale factor and zero g offset levels can be calibrated using the earth's gravity, as explained in the section "calibrating the ADXL150/ADXL250."

### Using the Zero g "Quick-Cal" Method

In Figure 18 (accelerometer alone, no external op amp), a trim potentiometer connects directly to the accelerometer's zero g null pin. The "quick offset calibration" scheme shown in Figure 17 is preferred over using a potentiometer, which could change its setting over time due to vibration. The "quick offset calibration" method requires measuring only the output voltage of the ADXL150/ADXL250 while it is oriented normal to the earth's gravity. Then, by using the simple equations shown in the figures, the correct resistance value for R2 can be calculated. In Figure 17, an external op amp is used to amplify the signal. A resistor, R2, is connected to the op amp's summing junction. The other side of R2 connects to either ground or +Vs depending on which direction the offset needs to be shifted.

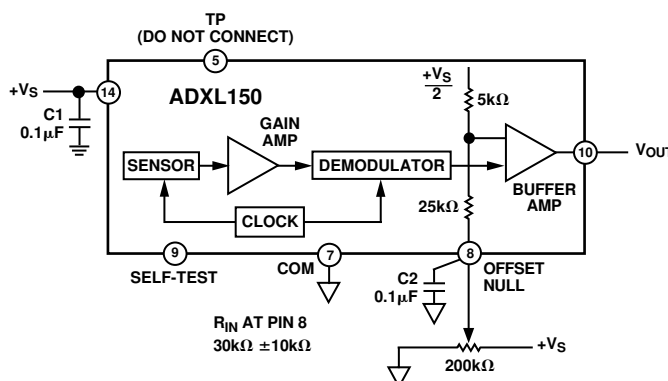

Figure 18. Offset Nulling the ADXL150/ADXL250 Using a Trim Potentiometer

# ADXL150/ADXL250

## DEVICE BANDWIDTH VS. MEASUREMENT RESOLUTION

Although an accelerometer is usually specified according to its full-scale  $g$  level, the limiting resolution of the device, i.e., its minimum discernible input level, is extremely important when measuring low  $g$  accelerations.

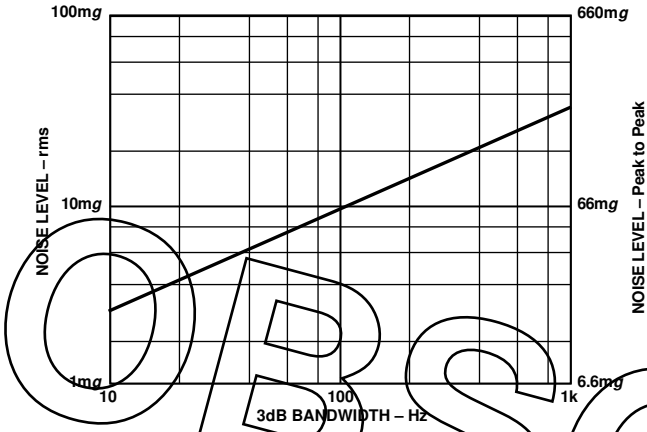

Figure 19. ADXL150/ADXL250 Noise Level vs. 3 dB Bandwidth (Using a “Brickwall” Filter)

The limiting resolution is predominantly set by the measurement noise “floor,” which includes the ambient background noise and the noise of the ADXL150/ADXL250 itself. The level of the noise floor varies directly with the bandwidth of the measurement. As the measurement bandwidth is reduced, the noise floor drops, improving the signal-to-noise ratio of the measurement and increasing its resolution.

The bandwidth of the accelerometer can be easily reduced by adding low-pass or bandpass filtering. Figure 19 shows the typical noise vs. bandwidth characteristic of the ADXL150/ADXL250.

The output noise of the ADXL150/ADXL250 scales with the square root of the measurement bandwidth. With a single pole roll-off, the equivalent rms noise bandwidth is  $\pi$  divided by 2 or

approximately 1.6 times the 3 dB bandwidth. For example, the typical rms noise of the ADXL150 using a 100 Hz one pole post filter is:

$$\text{Noise (rms)} = 1 \text{ mg}/\sqrt{\text{Hz}} \times \sqrt{100(1.6)} = 12.25 \text{ mg}$$

Because the ADXL150/ADXL250’s noise is, for all practical purposes, Gaussian in amplitude distribution, the highest noise amplitudes have the smallest (yet nonzero) probability. Peak-to-peak noise is therefore difficult to measure and can only be estimated due to its statistical nature. Table I is useful for estimating the probabilities of exceeding various peak values, given the rms value.

Table I.

Nominal Peak-to-Peak Value	% of Time that Noise Will Exceed Nominal Peak-to-Peak Value
2.0 × rms	32%
4.0 × rms	4.6%
6.0 × rms	0.27%
6.6 × rms	0.1%
8.0 × rms	0.006%

RMS and peak-to-peak noise (for 0.1% uncertainty) for various bandwidths are estimated in Figure 19. As shown by the figure, device noise drops dramatically as the operating bandwidth is reduced. For example, when operated in a 1 kHz bandwidth, the ADXL150/ADXL250 typically have an rms noise level of 32 mg. When the device bandwidth is rolled off to 100 Hz, the noise level is reduced to approximately 10 mg.

Alternatively, the signal-to-noise ratio may be improved considerably by using a microprocessor to perform multiple measurements and then to compute the average signal level.

### Low-Pass Filtering

The bandwidth of the accelerometer can easily be reduced by using post filtering. Figure 20 shows how the buffer amplifier can be connected to provide 1-pole post filtering, zero  $g$  offset trimming, and output scaling. The table provides practical component values

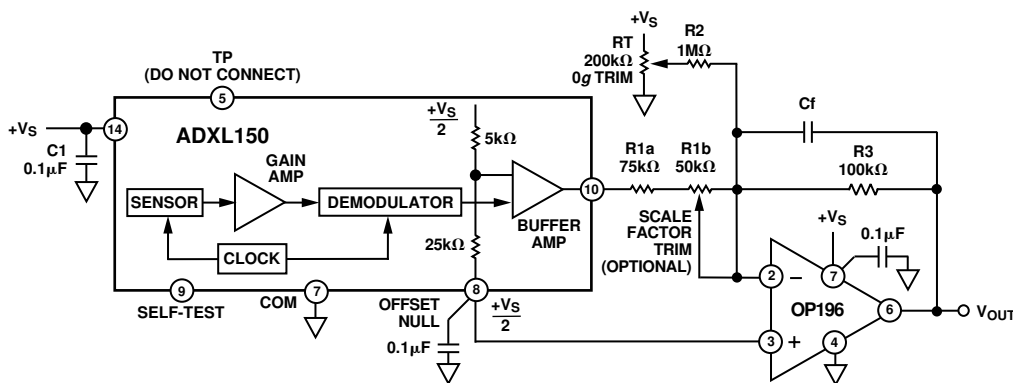

DESIRED OUTPUT SCALE FACTOR	F.S. RANGE	EXT AMP GAIN	R3 VALUE	Cf (μF) 100Hz	Cf (μF) 30Hz	Cf (μF) 10Hz
76mV/g	±25g	2.0	200kΩ	0.0082	0.027	0.082
100mV/g	±20g	2.6	261kΩ	0.0056	0.022	0.056
200mV/g	±10g	5.3	536kΩ	0.0033	0.010	0.033
400mV/g	±5g	10.5	1MΩ	0.0015	0.0056	0.015

Figure 20. One-Pole Post Filter Circuit with SF and Zero  $g$  Offset Trims

for various full-scale  $g$  levels and approximate circuit bandwidths. For bandwidths other than those listed, use the formula:

$$C_f = \frac{1}{(2\pi R3) \text{ Desired } 3\text{dB Bandwidth in Hz}}$$

or simply scale the value of capacitor  $C_f$  accordingly; i.e., for an application with a 50 Hz bandwidth, the value of  $C_f$  will need to be twice as large as its 100 Hz value. If further noise reduction is needed while maintaining the maximum possible bandwidth, a 2- or 3-pole post filter is recommended. These provide a much steeper roll-off of noise above the pole frequency. Figure 21 shows a circuit that provides 2-pole post filtering. Component values for the 2-pole filter were selected to operate the first op amp at unity gain. Capacitors  $C_3$  and  $C_4$  were chosen to provide 3 dB bandwidths of 10 Hz, 30 Hz, 100 Hz and 300 Hz.

The second op amp offsets and scales the output to provide a  $+2.5 \text{ V} \pm 2 \text{ V}$  output over a wide range of full-scale  $g$  levels.

### APPLICATION HINTS

#### ADXL250 Power Supply Pins

When wiring the ADXL250, be sure to connect BOTH power supply terminals, Pins 14 and 13.

#### Ratiometric Operation

Ratiometric operation means that the circuit uses the power supply as its voltage reference. If the supply voltage varies, the accelerometer and the other circuit components (such as an ADC, etc.) track each other and compensate for the change.

Figure 22 shows how both the zero  $g$  offset and output sensitivity of the ADXL150/ADXL250 vary with changes in supply voltage. If they are to be used with nonratiometric devices, such as an ADC with a built-in 5 V reference, then both components should be referenced to the same source, in this case the ADC reference. Alternatively, the circuit can be powered from an external +5 volt reference.

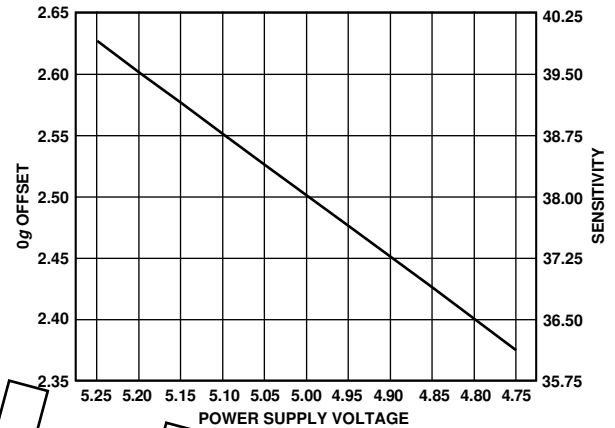

Figure 22. Typical Ratiometric Operation

Since any voltage variation is transferred to the accelerometer's output, it is important to reduce any power supply noise. Simply following good engineering practice of bypassing the power supply right at Pin 14 of the ADXL150/ADXL250 with a  $0.1 \mu\text{F}$  capacitor should be sufficient.

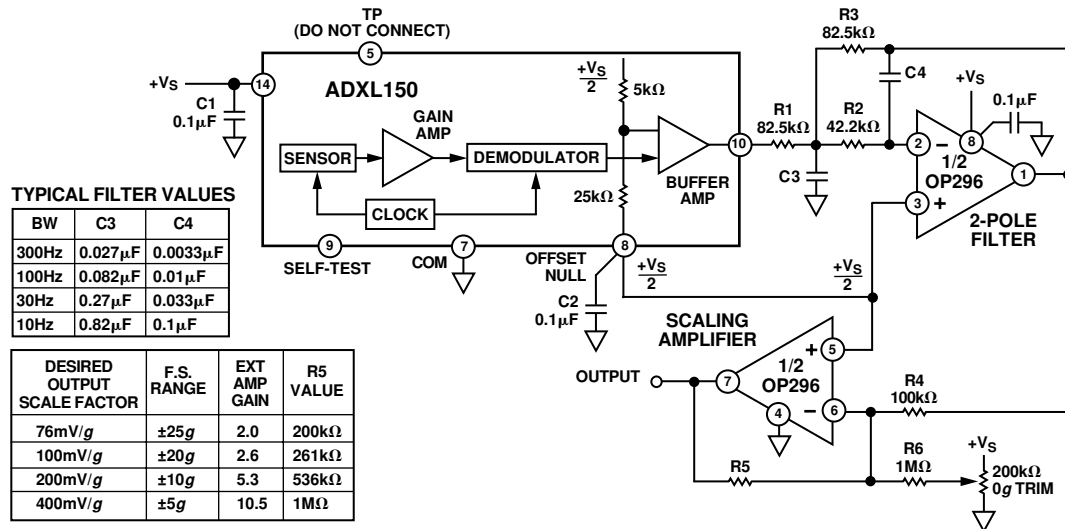

Figure 21. Two-Pole Post Filter Circuit

# ADXL150/ADXL250

## Additional Noise Reduction Techniques

Shielded wire should be used for connecting the accelerometer to any circuitry that is more than a few inches away—to avoid 60 Hz pickup from ac line voltage. Ground the cable’s shield at only one end and connect a separate common lead between the circuits; this will help to prevent ground loops. Also, if the accelerometer is inside a metal enclosure, this should be grounded as well.

## Mounting Fixture Resonances

A common source of error in acceleration sensing is resonance of the mounting fixture. For example, the circuit board that the ADXL150/ADXL250 mounts to may have resonant frequencies in the same range as the signals of interest. This could cause the signals measured to be larger than they really are. A common solution to this problem is to damp these resonances by mounting the ADXL150/ADXL250 near a mounting post or by adding extra screws to hold the board more securely in place.

When testing the accelerometer in your end application, it is recommended that you test the application at a variety of frequencies to ensure that no major resonance problems exist.

## REDUCING POWER CONSUMPTION

The use of a simple power cycling circuit provides a dramatic reduction in the accelerometer’s average current consumption. In low bandwidth applications such as shipping recorders, a simple, low cost circuit can provide substantial power reduction.

If a microprocessor is available, it can supply a TTL clock pulse to toggle the accelerometer’s power on and off.

A 10% duty cycle, 1 ms on, 9 ms off, reduces the average current consumption of the accelerometer from 1.8 mA to 180  $\mu$ A, providing a power reduction of 90%.

Figure 23 shows the typical power-on settling time of the ADXL150/ADXL250.

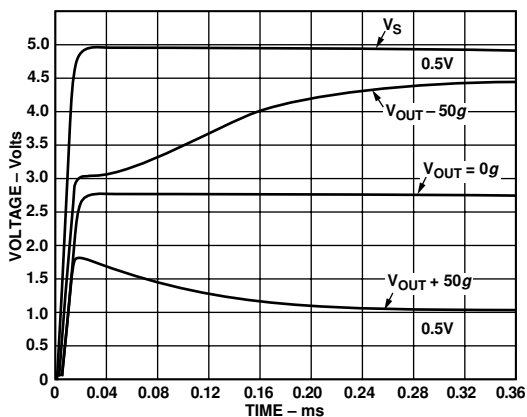

Figure 23. Typical Power-On Settling with Full-Scale Input. Time Constant of Post Filter Dominates the Response When a Signal Is Present.

## CALIBRATING THE ADXL150/ADXL250

If a calibrated shaker is not available, both the zero  $g$  level and scale factor of the ADXL150/ADXL250 may be easily set to fair accuracy by using a self-calibration technique based on the 1  $g$  acceleration of the earth’s gravity. Figure 24 shows how gravity and package orientation affect the ADXL150/ADXL250’s output. With its axis of sensitivity in the vertical plane, the ADXL150/ADXL250 should register a 1  $g$  acceleration, either positive or negative, depending on orientation. With the axis of sensitivity in the horizontal plane, no acceleration (the zero  $g$  bias level) should be indicated. The use of an external buffer amplifier may invert the polarity of the signal.

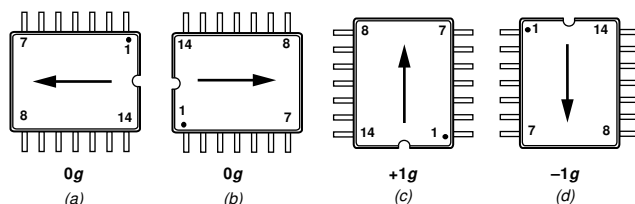

Figure 24. Using the Earth’s Gravity to Self-Calibrate the ADXL150/ADXL250

Figure 24 shows how to self-calibrate the ADXL150/ADXL250. Place the accelerometer on its side with its axis of sensitivity oriented as shown in “a.” (For the ADXL250 this would be the “X” axis—its “Y” axis is calibrated in the same manner, but the part is rotated 90° clockwise.) The zero  $g$  offset potentiometer RT is then roughly adjusted for midscale: +2.5 V at the external amp output (see Figure 20).

Next, the package axis should be oriented as in “c” (pointing down) and the output reading noted. The package axis should then be rotated 180° to position “d” and the scale factor potentiometer, R1b, adjusted so that the output voltage indicates a change of 2  $g$ s in acceleration. For example, if the circuit scale factor at the external buffer’s output is 100 mV per  $g$ , the scale factor trim should be adjusted so that an output change of 200 mV is indicated.

## Self-Test Function

A Logic “1” applied to the self-test (ST) input will cause an electrostatic force to be applied to the sensor that will cause it to deflect. If the accelerometer is experiencing an acceleration when the self-test is initiated, the output will equal the algebraic sum of the two inputs. The output will stay at the self-test level as long as the ST input remains high, and will return to the actual acceleration level when the ST voltage is removed.

Using an external amplifier to increase output scale factor may cause the self-test output to overdrive the buffer into saturation. The self-test may still be used in this case, but the change in the output must then be monitored at the accelerometer’s output instead of the external amplifier’s output.

Note that the value of the self-test delta is not an exact indication of the sensitivity (mV/ $g$ ) and therefore may not be used to calibrate the device for sensitivity error.

## MINIMIZING EMI/RFI

The architecture of the ADXL150/ADXL250, and its use of synchronous demodulation, makes the device immune to most electromagnetic (EMI) and radio frequency (RFI) interference. The use of synchronous demodulation allows the circuit to reject all signals except those at the frequency of the oscillator driving the sensor element. However, the ADXL150/ADXL250 have a sensitivity to noise on the supply lines that is near its internal clock frequency (approximately 100 kHz) or its odd harmonics and can exhibit baseband errors at the output. These error signals are the beat frequency signals between the clock and the supply noise.

Such noise can be generated by digital switching elsewhere in the system and must be attenuated by proper bypassing. By inserting a small value resistor between the accelerometer and its power supply, an RC filter is created. This consists of the resistor and the accelerometer's normal 0.1  $\mu\text{F}$  bypass capacitor. For example if  $R = 20 \Omega$  and  $C = 0.1 \mu\text{F}$ , a filter with a pole at 80 kHz is created, which is adequate to attenuate noise on the supply from most digital circuits, with proper ground and supply layout.

Power supply decoupling, short component leads, physically small (surface mount, etc.) components and attention to good grounding practices all help to prevent RFI and EMI problems. Good grounding practices include having separate analog and digital grounds (as well as separate power supplies or very good decoupling) on the printed circuit boards.

## INTERFACING THE ADXL150/ADXL250 SERIES *iMEMS* ACCELEROMETERS WITH POPULAR ANALOG-TO-DIGITAL CONVERTERS.

### Basic Issues

The ADXL150/ADXL250 Series accelerometers were designed to drive popular analog-to-digital converters (ADCs) directly. In applications where both a  $\pm 50 g$  full-scale measurement range and a 1 kHz bandwidth are needed, the  $V_{\text{OUT}}$  terminal of the accelerometer is simply connected to the  $V_{\text{IN}}$  terminal of the ADC as shown in Figure 25a. The accelerometer provides its (nominal) factory preset scale factor of  $+2.5 \text{ V} \pm 38 \text{ mV/g}$  which drives the ADC input with  $+2.5 \text{ V} \pm 1.9 \text{ V}$  when measuring a 50 g full-scale signal ( $38 \text{ mV/g} \times 50 g = 1.9 \text{ V}$ ).

As stated earlier, the use of post filtering will dramatically improve the accelerometer's low g resolution. Figure 25b shows a simple post filter connected between the accelerometer and the ADC. This connection, although easy to implement, will require fairly large values of  $C_f$ , and the accelerometer's signal will be loaded down (causing a scale factor error) unless the ADC's input impedance is much greater than the value of  $R_f$ . ADC input impedance's range from less than 1.5 k $\Omega$  up to greater than 15 k $\Omega$  with 5 k $\Omega$  values being typical. Figure 25c is the preferred connection for implementing low-pass filtering with the added advantage of providing an increase in scale factor, if desired.

### Calculating ADC Requirements

The resolution of commercial ADCs is specified in bits. In an ADC, the available resolution equals  $2^n$ , where  $n$  is the number of bits. For example, an 8-bit converter provides a resolution of  $2^8$  which equals 256. So the full-scale input range of the converter divided by 256 will equal the smallest signal it can resolve.

In selecting an appropriate ADC to use with our accelerometer we need to find a device that has a resolution better than the measurement resolution but, for economy's sake, not a great deal better.

For most applications, an 8- or 10-bit converter is appropriate. The decision to use a 10-bit converter alone, or to use a gain stage together with an 8-bit converter, depends on which is more important: component cost or parts count and ease of assembly.

Table II shows some of the tradeoffs involved.

**Table II.**

	8-Bit Converter and Op Amp Preamp	10-Bit (or 12-Bit) Converter
Advantages:	Low Cost Converter	No Zero g Trim Required
Disadvantages:	Needs Op Amp Needs Zero g Trim	Higher Cost Converter

Adding amplification between the accelerometer and the ADC will reduce the circuit's full-scale input range but will greatly reduce the resolution requirements (and therefore the cost) of the ADC. For example, using an op amp with a gain of 5.3 following the accelerometer will increase the input drive to the ADC from 38 mV/g to 200 mV/g. Since the signal has been gained up, but the maximum full-scale (clipping) level is still the same, the dynamic range of the measurement has also been reduced by 5.3.

**Table III. Typical System Resolution Using Some Popular ADCs Being Driven with and without an Op Amp Preamp**

Converter Type	$2^n$	Converter mV/Bit (5 V/ $2^n$ )	Preamp Gain	SF in mV/g	FS Range in g's	System Resolution in g's (p-p)
8 Bit	256	19.5 mV	None	38	$\pm 50$	0.51
	256	19.5 mV	2	76	$\pm 25$	0.26
	256	19.5 mV	2.63	100	$\pm 20$	0.20
10 Bit	256	19.5 mV	5.26	200	$\pm 10$	0.10
	1,024	4.9 mV	None	38	$\pm 50$	0.13
	1,024	4.9 mV	2	76	$\pm 25$	0.06
	1,024	4.9 mV	2.63	100	$\pm 20$	0.05
12 Bit	1,024	4.9 mV	5.26	200	$\pm 10$	0.02
	4,096	1.2 mV	None	38	$\pm 50$	0.03
	4,096	1.2 mV	2	76	$\pm 25$	0.02
	4,096	1.2 mV	2.63	100	$\pm 20$	0.01
	4,096	1.2 mV	5.26	200	$\pm 10$	0.006

Table III is a chart showing the required ADC resolution vs. the scale factor of the accelerometer with or without a gain amplifier. Note that the system resolution specified in the table refers

# ADXL150/ADXL250

to that provided by the converter and preamp (if used). It is necessary to use sufficient post filtering with the accelerometer to reduce its noise floor to allow full use of the converter’s resolution (see post filtering section).

The use of a gain stage following the accelerometer will normally require the user to adjust the zero  $g$  offset level (either by trimming or by resistor selection—see previous sections).

For many applications, a modern “economy priced” 10-bit converter, such as the AD7810 allows you to have high resolution without using a preamp or adding much to the overall circuit cost. In addition to simplicity and cost, it also meets two other necessary requirements: it operates from a single +5 V supply and is very low power.

OBSOLETE

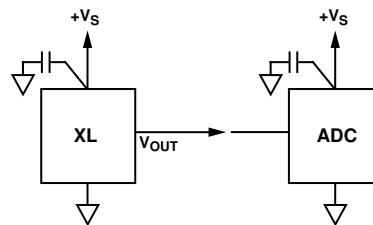

a. Direct Connection, No Signal Amplification or Post Filtering

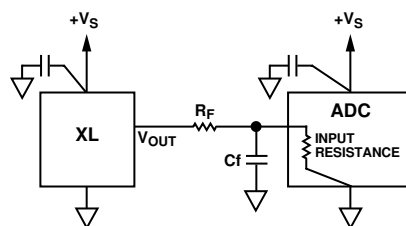

b. Single-Pole Post Filtering, No Signal Amplification

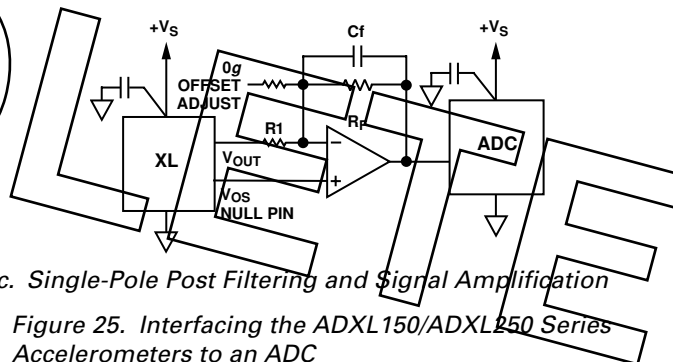

c. Single-Pole Post Filtering and Signal Amplification

Figure 25. Interfacing the ADXL150/ADXL250 Series Accelerometers to an ADC

OUTLINE DIMENSIONS

Dimensions shown in inches and (mm).

14-Lead Cerpac  
(QC-14)

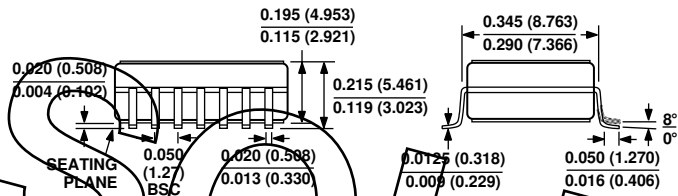
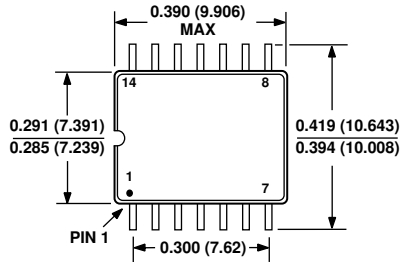

OBSOLETE